

Document Title		ZGS-10000-X-X Hydraulic Rescue Hoist Ground Support Equipment		
Document No.	Rev	Document Type	Release Date	
ZOM-10000-X	H	Operation & Maintenance Manual	Sept 20, 2022	



ZOM-10000-X

Hydraulic Rescue Hoist Ground Support Equipment

PN: ZGS-10000-X-X (All Hydraulic RHGSE Models)

Operation and Maintenance Manual

United States Patent # 7,429,031 B1



ZGS-10000-5-1 Mobile
Hydraulic RHGSE
*(Is shown with Optional
MagSens Head already
installed)*



ZGS-10000-10-X with
Work Platform and Four
Groove Capstans
*(Is shown with Optional
MagSens Head already
installed)*



ZGS-10000-X-CE with
Work Platform and Four
Groove Capstans
installed)

Document Title		ZGS-10000-X-X Hydraulic Rescue Hoist Ground Support Equipment		
Document No.	Rev	Document Type	Release Date	
ZOM-10000-X	H	Operation & Maintenance Manual	Sept 20, 2022	

Declaration of CE Conformity

This is to certify that the ZGS-10000-X-CE Rescue Hoist Ground Support Equipment

manufactured by:

Zephyr International LLC

5015 Enoch Rd

Conway, S.C 29526

USA

Meets the essential health and safety requirements of Directive 2006/42/EC relating to machinery.

In compliance with:

Substances (RoHS) established by 2011/65/EC.

GPSD 2001/95/EC

LVD 2014/35/EU

EN ISO 14119:2013

EN ISO 13849-1:2008

EN 60204-1:2018

EN ISO 13857:2008.

and meets the requirements when used in accordance with the Operation and Maintenance Manual ZOM-10000-X Rev H which forms a part of this conformity statement.

The construction file is available at the address stated above.

Signed,



Michael Mitchell, President

Zephyr International LLC

09-08-2021

Page 2 of 85

Document Title		ZGS-10000-X-X Hydraulic Rescue Hoist Ground Support Equipment		
Document No.	Rev	Document Type	Release Date	
ZOM-10000-X	H	Operation & Maintenance Manual	Sept 20, 2022	

1 Manual Information

1.1 Support

Please contact Zephyr International LLC with any questions.

Zephyr Technical Support

Email: info@zephyrintl.com

Phone: 1-843-365-2675

Online Support

Visit website at www.zephyrintl.com

- Sign up for the Members Only section, browse available information and resources.
- Register your serial number information and identify a point of contact for future service bulletin release(s).

1.2 Definitions



Shall be used when there is risk of injury or death to personnel.



Shall be used when there is risk of damage to equipment.

NOTE:

Shall be used to highlight essential procedures or statements which may facilitate performance of a procedure or operation.

1.3 Symbols

	Warning		Warning Electrical Hazard
	Warning Hot Surface Burn Hazard		Warning Lifting Hazard
	Warning Moving Parts		Warning Strong Magnetic Field
	Must Wear Eye Protection		Must Wear Hand Protection
	Switch Off Before Operating		Must Wear Hearing Protection

Document Title		ZGS-10000-X-X Hydraulic Rescue Hoist Ground Support Equipment		
Document No.	Rev	Document Type	Release Date	
ZOM-10000-X	H	Operation & Maintenance Manual	Sept 20, 2022	

1.4 Safety Precautions



Before operation of the Rescue Hoist Ground Support Equipment (RHGSE), thoroughly review the entire manual to prevent injury or damage to the rescue hoist, helicopter, or RHGSE.

Never operate the RHGSE with loose clothing, jewelry, ties, long hair, or anything that may become entangled.



Always Observe the rescue hoist cable always and be prepared to stop at any time.

Control Section Displays are sealed with gaskets, but while water washing, do not hit the displays directly with a stream of water or some moisture may get inside, damaging the displays.

Never store the RHGSE under a plastic bag, especially in humid or wet weather conditions, as it may trap moisture and cause the capstans to swell. If this occurs the capstans will need to be replaced before operating the RHGSE.

1.5 Table of Contents

1 Manual Information	3
1.1 Support	3
1.2 Definitions	3
1.3 Symbols	3
1.4 Safety Precautions	4
1.5 Table of Contents	4
1.6 Table of Figures	6
1.7 Appendices	7
2 Product Support	8
2.1 Members Only Website	8
2.2 Product Support for Zephyr RHGSE	8
3 Introduction	9
3.1 Manual Introduction	9
3.2 Purpose of the Equipment	10
3.3 Theory of Operation	10
4 Component Data	11
4.1 Hydraulic RHGSE Diagram - Front	11
4.2 Hydraulic RHGSE Diagram – Rear	12
4.3 Tow Handle	13
4.4 Swivel Locks	13
4.5 Caster Brakes	13
4.6 Capstans	14
4.7 Safety Covers	14
4.8 Safety Sensors	15
4.9 Pressure and Exit Roller Assemblies	15

Document Title		ZGS-10000-X-X Hydraulic Rescue Hoist Ground Support Equipment		
Document No.	Rev	Document Type	Release Date	
ZOM-10000-X	H	Operation & Maintenance Manual	Sept 20, 2022	

4.10 Guide Rollers	16
4.11 Rotatub and Spooler	16
4.12 Lubridryer Assembly	16
4.13 Air Compressor	17
4.14 Main Batteries	17
4.15 Battery Charger	17
4.16 Battery Select Switch & Alternate Power Adapter	18
4.17 Hydraulic Drive System	18
4.18 Control Station & Rocker Switch	19
4.19 600 lb. Hook Check Point	20
4.20 Hydraulic Tote Kit & Spare Parts	20
4.21 MagSens System	20
5 Operation of the RHGSE	21
5.1 Augmentation Codes	21
5.2 Operation Warnings	21
5.3 RHGSE Setup	22
5.4 Extending Operation.	28
5.5 Retracting Operation.	29
5.6 600 lb. Hook Check.	34
5.7 Rescue Hoist Cable Removal.	36
5.8 Rescue Hoist Cable Installation.	37
6 Maintenance Tasks	39
7 Illustrated Parts Breakdown	40
8 Technical Support	84
9 Document Revision History	85

Document Title		ZGS-10000-X-X Hydraulic Rescue Hoist Ground Support Equipment		
Document No.	Rev	Document Type	Release Date	
ZOM-10000-X	H	Operation & Maintenance Manual	Sept 20, 2022	

1.6 Table of Figures

Figure 1 - Improper Pre-tensioning	10
Figure 2 - Proper Pre-tensioning	10
Figure 3 - Hydraulic RHGSE Diagram - Front.....	11
Figure 4 - Hydraulic RHGSE Diagram - Rear.....	12
Figure 5 - Tow Handle	13
Figure 6 - Swivel Locks	13
Figure 7 - Caster Brakes	13
Figure 8 - 3 Groove Capstans	14
Figure 9 - 4 Groove Capstans	14
Figure 10 - Safety Covers	14
Figure 11 - Safety Sensors.....	15
Figure 12 - Pressure and Exit Roller	15
Figure 13 - Guide Rollers	16
Figure 14 - Tub and Spooler	16
Figure 15 - Lubridryer.....	16
Figure 16 - Air Compressor	17
Figure 17 - Main Batteries	17
Figure 18 - Battery Charger.....	17
Figure 19 - Battery Select Switch & Alternate Power Adapter	18
Figure 20 - Hydraulic Drive System.....	18
Figure 21 - Retract Load Adjustment	18
Figure 22 - Control Station - Digital Displays	19
Figure 23 - Control Station - User Interface	19
Figure 24 - Rocker Switch	19
Figure 25 - 600 lb. Hook Check Point	20
Figure 26 - Hydraulic Tote Kit.....	20
Figure 27 - MagSens System.....	20
Figure 28 - Positioning the RHGSE.....	22
Figure 29 - Slip Clutch Quick-Check	22
Figure 30 - Battery Select Switch & Alternate Power Adapter	23
Figure 31 - Swivel Locks	23
Figure 32 - Fill Tub w/ Fresh Water.....	23
Figure 33 - Hook Placement.....	24
Figure 34 - MagSens.....	24
Figure 35 - Cable in Lubridryer.....	25
Figure 36 - Cable in MagSens.....	25

Document Title		ZGS-10000-X-X Hydraulic Rescue Hoist Ground Support Equipment		
Document No.	Rev	Document Type	Release Date	
ZOM-10000-X	H	Operation & Maintenance Manual	Sept 20, 2022	

Figure 37 - Capstan Cable Wrap..... 25

Figure 38 - Exit & Pressure Rollers 26

Figure 39 - Close Safety Covers 26

Figure 40 - Guide Wheel Cable Routing 26

Figure 41 - Cable Routing 27

Figure 42 - Spooler Slot..... 27

Figure 43 - Hook Placement..... 27

Figure 44 - Digital Display Power Switch 27

Figure 45 - Load Adjustment 30

Figure 46 - Cable Removal 31

Figure 47 - Manual Retraction Point..... 32

Figure 48 - Manual Retraction 32

Figure 49 - Cable Retraction 33

Figure 50 - 600lb. Hook Check Setup 34

Figure 51 - Remove Slack 34

Figure 52 - 600 lb. Hook Check..... 35

Figure 53 - Stow Hook..... 35

Figure 54 - Detach Hook 35

Figure 55 - Lower Capstan Shaft 37

Figure 56 - Goodrich Adapter & Breeze Adapter Sleeve 37

Figure 57 - Breeze Configuration 37

Figure 58 - Goodrich Configuration 37

Figure 59 - Spooler Installation 37

Figure 60 - Maintenance Tasks Reference Table 39

1.7 Appendices

- Appendix A - Hydraulic Setup Guide (See detached file)
- Appendix B - Hydraulic Quick-Start Guide (See detached file)
- Appendix C - Hydraulic Maintenance (See detached file)
- Appendix D - Hydraulic RHGSE Maintenance Log (See detached file)
- Appendix E - Hydraulic RHGSE Reprogramming Displays (See detached file)
- Appendix F - Hydraulic RHGSE Spare Parts (See detached file)

Document Title		ZGS-10000-X-X Hydraulic Rescue Hoist Ground Support Equipment		
Document No.	Rev	Document Type	Release Date	
ZOM-10000-X	H	Operation & Maintenance Manual	Sept 20, 2022	

2 Product Support

2.1 Members Only Website

Visit our Members Only site that is accessible via Zephyr International's website at <http://www.zephyrintl.com>. Select the "Members Only" link at the top right of the website or go directly to <http://members.zephyrintl.com/>. Once there, select "Sign Up" and create a username and password. It is a very simply process and there are no costs involved.

Once logged in, go to "Product Info," and select "Hydraulic RHGSE." Through the Members Only website, customers have access to training videos, training presentations, service bulletins, a spare parts list, quick start guides and the latest manual revision. The training videos can help with recurring training. This portion of the website was just launched for you to benefit from and to be used as a valuable resource.

2.2 Product Support for Zephyr RHGSE

To ensure that we can contact you in case of any updates to the manual, service bulletins and/or updated information, it is highly recommended that you register your RHGSE with us, the serial number on the Hydraulic RHGSE is located on the control station. Please email us at info@zephyrintl.com the following information, or you can fax it to us 1-843-365-2677.

Zephyr RHGSE Model(s) _____

RHGSE Serial Number(s) of the _____

Organization Name: _____

Organization Address: _____

POC Name for receiving information on your Zephyr _____

POC Email to send information to _____

POC telephone _____

Date the RHGSE was received _____

NOTE: We would appreciate your feedback so that we may continue to improve upon the website, our equipment, and our customer support.

Document Title		ZGS-10000-X-X Hydraulic Rescue Hoist Ground Support Equipment		
Document No.	Rev	Document Type	Release Date	
ZOM-10000-X	H	Operation & Maintenance Manual	Sept 20, 2022	

3 Introduction

3.1 Manual Introduction

The purpose of this manual is to detail the best-known practices for operating the Zephyr International LLC. Hydraulic Rescue Hoist Ground Support Equipment (RHGSE). This manual covers the operation of all Zephyr part numbers beginning with “ZGS-10000.” There are several configurations of the Hydraulic RHGSE that have been fielded. Variations may include: 3 or 4 groove capstans, Work Platform and Safety Railing (ZGS-10457-x), Improved Safety features, or a MagSens Cable Inspection System (ZGS-15000-3). Regardless of the configuration, the overall operation of the RHGSE has changed little.

See the attached Appendices for expanded details:

- **Appendix A - Hydraulic Setup Guide.**
 - Detailed instructions on the proper methods for unpacking and assembling the Hydraulic RHGSE from the shipping crate.
- **Appendix B - Hydraulic Quick Start Guide.**
 - A step-by-step Quick-Start Guide for operating the Hydraulic RHGSE with minimal instructions.
- **Appendix C - Hydraulic Maintenance.**
 - Detailed instructions for performing necessary maintenance tasks for the Hydraulic RHGSE.
- **Appendix D - Hydraulic RHGSE Maintenance Log.**
 - A detailed Maintenance Log Card for tracking the Hydraulic RHGSE maintenance tasks.
- **Appendix E - Hydraulic RHGSE Reprogramming Displays.**
 - Detailed instructions for reprogramming the Load Digital Display on the Hydraulic RHGSE.
- **Appendix F - Hydraulic RHGSE Spare Parts.**
 - A Comprehensive list of spare parts required to properly maintain the Hydraulic RHGSE.

NOTE:

The Operations and Maintenance Manual, Appendices, and all related documents should be stored in the designated Manual holder located under the tow handle.

Document Title		ZGS-10000-X-X Hydraulic Rescue Hoist Ground Support Equipment		
Document No.	Rev	Document Type	Release Date	
ZOM-10000-X	H	Operation & Maintenance Manual	Sept 20, 2022	

3.2 Purpose of the Equipment

The RHGSE is designed to simplify the inspection and maintenance of the rescue hoist and the rescue hoist cable by applying user-controlled loads on the rescue hoist system. It is designed to be used on the ground and mitigates the need to fly the aircraft to accomplish certain rescue hoist maintenance tasks.

The RHGSE applies a constant load to the rescue hoist cable while extending and retracting, which ensures consistent and tight layer wraps. Tight layer wraps will extend the life of the rescue hoist cable by eliminating shock loading, scrubbing, and crushing of lower layers. Pre-tensioning—or “re-seating”—restores tension to the lower layers. This reduces the risk of the rescue hoist cable abrading itself when a heavy load is applied.

In Figure 1 - Improper Pre-tensioning, the four lower layers are tensioned improperly and get crushed by the tightly wound top layers. This can cause damage and could shorten the life of the cable. In Figure 2 - Proper Pre-tensioning the cable was pre-tensioned properly and all layers will retain their round shape when a heavy load is applied.

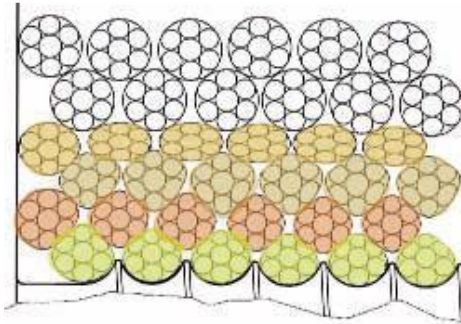

Figure 1 - Improper Pre-tensioning

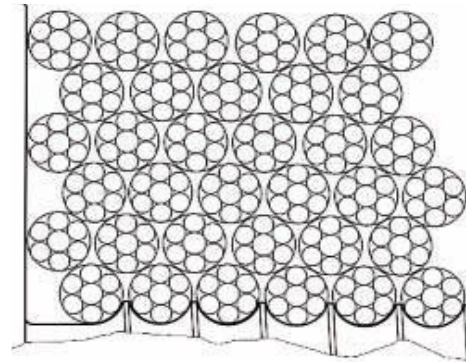



Figure 2 - Proper Pre-tensioning

3.3 Theory of Operation

The Hydraulic RHGSE is designed to apply a pre-set load of 100 lbs. while extending, and a manually adjustable load of 20—600 lbs. while retracting. The rescue hoist cable gets paid out of the hoist and tightly wrapped onto the grooved rubber Capstans. The remainder of the cable gets routed down into the Tub and Spooler where it and the rescue hook are safely stored. During the “extend” phase, the RHGSE hydraulic system is pulling the cable off the hoist at a steady load and neatly wraps it into the Tub and Spooler. During the “retract” phase, the rescue hoist is pulling the cable out of the RHGSE while the hydraulics system is producing the resistance needed to achieve the desired test load set by a technician.

Document Title		ZGS-10000-X-X Hydraulic Rescue Hoist Ground Support Equipment		
Document No.	Rev	Document Type	Release Date	
ZOM-10000-X	H	Operation & Maintenance Manual	Sept 20, 2022	

4 Component Data

4.1 Hydraulic RHGSE Diagram - Front

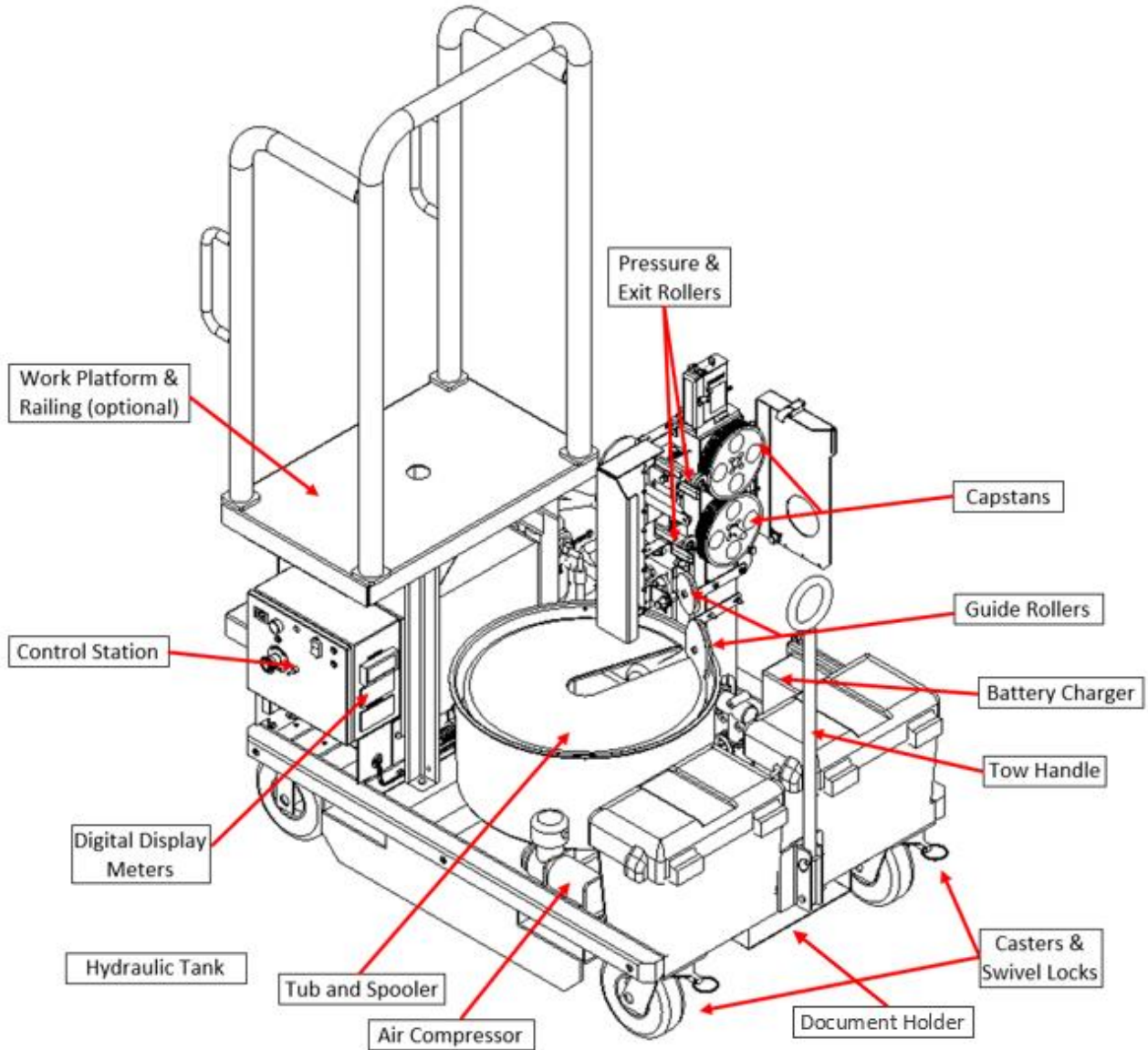



Figure 3 - Hydraulic RHGSE Diagram - Front

Document Title		ZGS-10000-X-X Hydraulic Rescue Hoist Ground Support Equipment		
Document No.	Rev	Document Type	Release Date	
ZOM-10000-X	H	Operation & Maintenance Manual	Sept 20, 2022	

4.2 Hydraulic RHGSE Diagram – Rear

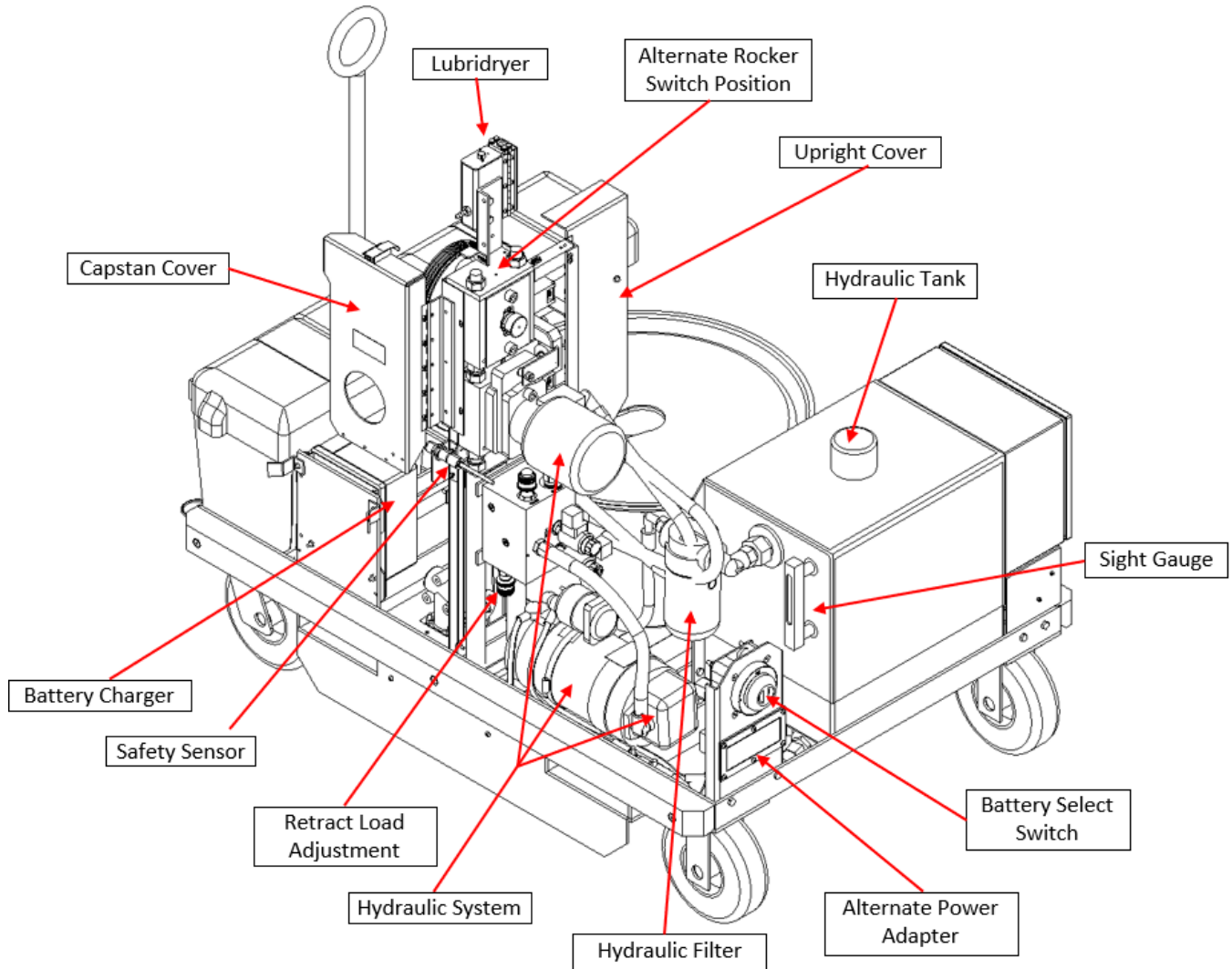



Figure 4 - Hydraulic RHGSE Diagram - Rear

Document Title		ZGS-10000-X-X Hydraulic Rescue Hoist Ground Support Equipment		
Document No.	Rev	Document Type	Release Date	
ZOM-10000-X	H	Operation & Maintenance Manual	Sept 20, 2022	

4.3 Tow Handle

 **WARNING**

Always lock the RHGSE Tow Handle in the upright position when not in use to prevent a tripping hazard or allowing it to inadvertently fall. Failure to do so could cause injury, or cause damage to the aircraft, rescue hoist and RHGSE.

- The tow handle can be used manually or attached to a vehicle for flightline transportation.
- There is a locking pin attached to the tow handle weldment by a lanyard to allow the tow handle to lock in the upright position.



Figure 5 - Tow Handle

4.4 Swivel Locks

 **WARNING**

The Swivel Locks should remain locked while the RHGSE is in use. This ensures the caster orientation remains in-line with the RHGSE frame and prevents the RHGSE from shifting towards the airframe. Failure to do so could cause injury, or damage the aircraft, hoist, and RHGSE.

- The Swivel Locks can be utilized to prevent the front wheels of the RHGSE from rotating. The wheels can be locked in four cardinal directions.
- Pull the Key Ring out and rotate it 90 degrees to lock/unlock.
- Locked: Horizontal key ring alignment. See Figure 6.
- Un-locked: Vertical key ring alignment.
- The Swivel Locks should remain locked while the unit is stationary.
- The Swivel Locks should be unlocked while moving the RHGSE around the hanger or flightline.



Figure 6 - Swivel Locks

4.5 Caster Brakes

NOTE:

The caster brakes should be unlocked during operation of the RHGSE to allow the equipment to move freely with the cable, as it extends and retracts.

- The Caster Locks can be used to prevent unwanted movement from the RHGSE.
- Actuate the Foot Peddle to engage/disengage the Caster Brakes.
- Engaged: Peddle in **DOWN** position.
- Disengaged: Peddle in **UP** position. See Figure 7.
- The Caster Brakes should remain locked while the unit is not in use.
- The Swivel Locks should be unlocked while moving the RHGSE around, or while using the RHGSE unless otherwise impractical.

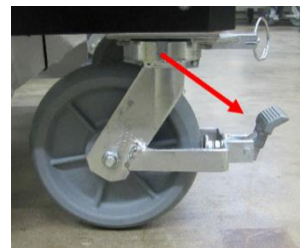



Figure 7 - Caster Brakes

Document Title		ZGS-10000-X-X Hydraulic Rescue Hoist Ground Support Equipment		
Document No.	Rev	Document Type	Release Date	
ZOM-10000-X	H	Operation & Maintenance Manual	Sept 20, 2022	

4.6 Capstans

CAUTION

Capstans are life and wear limited items. Always ensure that they meet the specified tolerances dictated by Appendix C. Continued use of Capstans that do not satisfy the tolerance specifications could cause damage to the aircraft, hoist, or RHGSE.

Capstans are subject to environmental damage. Reduce environmental exposure to extend the service life. Failure to do so could cause damage to the aircraft, hoist, or RHGSE. See Appendix C for detailed storage instructions.

- The Capstans are a friction device. The rescue hoist cable is wrapped tightly around them, which allows Torsional energy from the hydraulics system to be turned into tension and loading of the rescue hoist cable.
- The Hydraulic RHGSE can use either three groove Capstans (Figure 8) or four groove Capstans (Figure 9).
- For the three grooves versions the upper capstan and the lower capstans are made of different hardness material. The lower three groove capstan (black) is harder to accommodate the higher loads, and the upper three groove capstan (orange) is softer to provide sufficient grip on the cable. See Figure 8.
- The four groove capstans incorporate the addition of a steel first groove to improve the wear life. Both upper and lower capstans use the same urethane material. See Figure 9.
- Each capstan is serialized and marked with a date of manufacture (DOM) in mm/yy format .

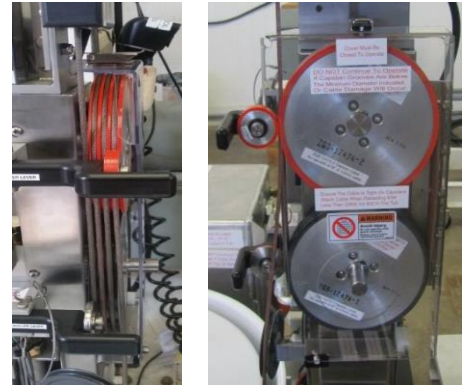

Figure 8 - 3 Groove Capstans

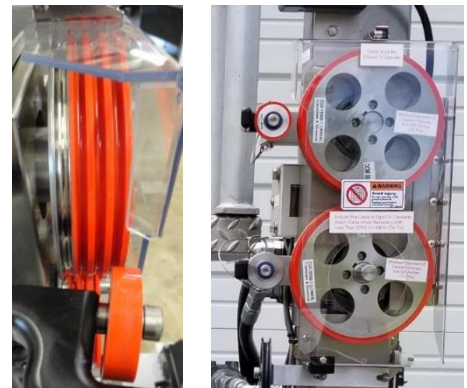

Figure 9 - 4 Groove Capstans

4.7 Safety Covers

WARNING

Never attempt to bypass, disable, or remove any safety covers, sensors, or systems on the RHGSE. Doing so could cause injury or damage to the aircraft, hoist, or RHGSE.

- The Safety Covers are designed to remove the risk of entanglement and other severe injury risks.
- There are two separate safety covers that are incorporated into RHGSE depending on configuration, the Capstan Cover (right) and the optional Upright Cover (left). See Figure 10.



Figure 10 - Safety Covers

Document Title		ZGS-10000-X-X Hydraulic Rescue Hoist Ground Support Equipment		
Document No.	Rev	Document Type	Release Date	
ZOM-10000-X	H	Operation & Maintenance Manual	Sept 20, 2022	

4.8 Safety Sensors

WARNING

Never attempt to bypass, disable, or remove any safety covers, sensors, or systems on the RHGSE. Doing so could cause injury or damage to the aircraft, hoist, or RHGSE.

- There are two styles of Safety Sensors on various configurations of the RHGSE, a mechanical style limit switch (top) and a magnetic style proximity sensor (bottom). See Figure 11.
- The Safety Sensors ensure that the Capstan Cover and Upright Cover are closed during operation. If opened during operation, the RHGSE will immediately turn off.

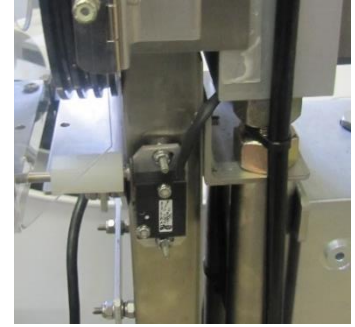

Figure 11 - Safety Sensors

4.9 Pressure and Exit Roller Assemblies

WARNING

Do not lean on the Pressure or Exit Roller Assemblies. Failure to do so could cause injury and damage the assembly.

CAUTION

The Pressure and Exit Rollers should remain in the locked open position while not in use. Failure to do so could damage them or the Capstans.

The Exit Rollers is a life and wear limited item. Always ensure the that it meets the specified tolerances dictated by Appendix C. Continued use of an Exit Roller that does not satisfy the tolerance specifications could cause damage to the hoist or RHGSE.

The Exit Roller is subject to sun and humidity damage. Reduce environmental exposure to extend the service life. Failure to do so could cause damage to the aircraft, hoist, or RHGSE. See Appendix C for detailed storage instructions.

- The Pressure Roller assembly (lower) and the Exit Roller Assembly (upper) apply force to the rescue hoist cable to ensure that it remains properly seated in the Capstan grooves. See Figure 12.
- Each assembly can be locked open with the quick release pin that is tethered to the respective clevis pin. Both assemblies should be unlocked and applying force when the RHGSE is in use.



Figure 12 - Pressure and Exit Roller

Document Title		ZGS-10000-X-X Hydraulic Rescue Hoist Ground Support Equipment		
Document No.	Rev	Document Type	Release Date	
ZOM-10000-X	H	Operation & Maintenance Manual	Sept 20, 2022	

4.10 Guide Rollers

⚠ CAUTION

Never continue to operate the RHGSE if the rescue hoist cable loses contact with the guide rollers. Doing so could cause damage to the rescue hoist cable.

- The Guide Rollers ensure the cable is wrapped neatly into the Tub and Spooler during extend and prevents the cable from spiraling out during retract operations.



Figure 13 - Guide Rollers

4.11 Rotatub and Spooler

NOTE:

The Rotatub and Spooler may come in assorted colors and configurations that are dependent on the revision level during the date of manufacture.

- The Tub and Spooler keep the rescue hoist cable neatly spooled and protected during the operation of the RHGSE.
- The Rotatub will accommodate any installed rescue hook, hand wheel, crushable bumper or all three if they are attached to the end of the cable and will accommodate up to 300ft. (91.44m) of cable.



Figure 14 - Tub and Spooler

4.12 Lubridryer Assembly

⚠ CAUTION

Install new Lubridryer Pads at the beginning of each cycle and after the extend operation of a water rinse. Failure to do so could cause particulates or saline that was removed to be re-distributed onto the rescue hoist cable. This could cause damage to the rescue hoist and the cable.

- The Lubridryer Cleans the rescue hoist cable of small particulates, dries it, and helps re-lubricate the cable per OEM recommendations. See Figure 15.
- The Lubridryer uses disposable pads to wipe debris, or salt, off the cable. A container of 100 pads is supplied with the equipment.
- The Lubridryer uses compressed air to dry the rescue hoist cable.
- The cable can be lubricated by filling the oil reservoir with oil.



Figure 15 - Lubridryer

Document Title		ZGS-10000-X-X Hydraulic Rescue Hoist Ground Support Equipment		
Document No.	Rev	Document Type	Release Date	
ZOM-10000-X	H	Operation & Maintenance Manual	Sept 20, 2022	

4.13 Air Compressor

⚠ CAUTION

Do not allow water to enter the Air Compressor Inlet. Failure to do so will result in damage to the Air Compressor.

- The Air Compressor supplies the Lubridryer with compressed air to blow off any small particulates or water from the rescue hoist cable.



Figure 16 - Air Compressor

4.14 Main Batteries

⚠ WARNING

Do not overexert the Batteries or store them in extreme weather conditions. Doing so could initiate thermal runaway and cause the Batteries to overheat and burn/explode. This could cause injury or cause damage to the facility, aircraft, or RHGSE. Without sacrificing personal safety, unplug the RHGSE and move it OUTSIDE if possible.

⚠ CAUTION

Never operate the RHGSE with the battery covers removed. Doing so could cause damage to the aircraft, hoist, and RHGSE.

The Batteries are a life limited item. Never allow the voltage to drop below 10 VDC on a single Battery. Always ensure that it meets the specified tolerances dictated by Appendix C. Continued use of Batteries that do not satisfy the tolerance specifications could cause damage to the hoist or RHGSE.

The Batteries are subject to sun damage. Reduce environmental exposure to extend the service life. Failure to do so could cause damage to the aircraft, hoist, or RHGSE.

- The 24 VDC power system uses two 8A31DT 12 VDC Sealed Absorbed Glass Mat (AGM) lead acid batteries that are connected in series. See **Figure 17**.
- The batteries are air transportable and sealed to eliminate leakage.



Figure 17 - Main Batteries

4.15 Battery Charger

⚠ CAUTION

At minimum, the Battery Charger must be plugged in for 12 hours once a month. During operation, the battery charger should always be plugged in. Failure to do so could cause permanent damage to the batteries.

Always confirm that the wall outlet voltage matches the voltage specifications of the Battery Charger prior to hook up. Failure to do so could cause damage to the aircraft, hoist, and RHGSE.

- The integrated Battery Charger is a sealed computer regulated unit that monitors and charges each battery separately. See **Figure 18**.
- Multiple versions of chargers can be found on Hydraulic RHGSE depending on the configuration. See Appendix C for detailed maintenance and LED code explanations.



Figure 18 - Battery Charger

Document Title		ZGS-10000-X-X Hydraulic Rescue Hoist Ground Support Equipment		
Document No.	Rev	Document Type	Release Date	
ZOM-10000-X	H	Operation & Maintenance Manual	Sept 20, 2022	

4.16 Battery Select Switch & Alternate Power Adapter

CAUTION

Never operate the RHGSE with the Battery Select Switch in either the “BOTH” or “ALL” positions. Doing so could cause damage to the aircraft, hoist, and RHGSE.

- The Battery Select Switch & Alternate Power Adapter enable the utilization of an “Auxiliary Ground Power Unit” (AGPU) or other similar devices to power the Hydraulic RHGSE for extended use on the flightline, or when keeping the Battery Charger plugged in during operation is otherwise impossible.
- The Battery Select Switch toggles between the on-board batteries and the 28 VDC alternate power source.
 - Position #1: On-board Batteries
 - Position #2: Alternate Power Source.
 - Position “BOTH” and “ALL”: NEVER USE



Figure 19 - Battery Select Switch & Alternate Power Adapter

4.17 Hydraulic Drive System

CAUTION

The hydraulic fluid specification is marked on the hydraulic tank. Mixing different types of hydraulic fluid is NOT recommended. Doing so could cause damage to the hoist and RHGSE.

- The RHGSE Hydraulic System is a closed hydraulic circuit comprised of a 12 gal. Tank, 24 VDC Motor and Pump, Manifold, Motor, and Filter. This system produces the torsional force required to create heavy loads on the rescue hoist cable.
- The system uses ten gallons of Mil-H-83282 hydraulic fluid.
- The Hydraulic Filter is equipped with a visual replacement indicator.
- The Retract Load Adjustment knob can be found on the bottom of the Hydraulic Manifold. It is used to manually adjust “Retract” load while operating the RHGSE. Turn the Retract Load Adjustment knob clockwise to increase and counterclockwise to decrease the load.

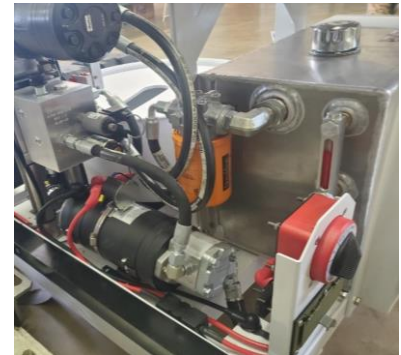



Figure 20 - Hydraulic Drive System



Figure 21 - Retract Load Adjustment

Document Title		ZGS-10000-X-X Hydraulic Rescue Hoist Ground Support Equipment		
Document No.	Rev	Document Type	Release Date	
ZOM-10000-X	H	Operation & Maintenance Manual	Sept 20, 2022	

4.18 Control Station & Rocker Switch

WARNING

Always actuate the Extend/Retract Rocker Switch to the “OFF” position when ceasing operation. Disabling the RHGSE by other means is dangerous as it could cause the RHGSE to start suddenly once power is restored. Failure to do so could cause injury or damage the aircraft, hoist, and RHGSE.

CAUTION

The displays are for reference only. Always pay close attention to the hoist and RHGSE while operating the RHGSE to ensure enough cable length is remaining in the Tub and Spooler. Failure to do so could cause damage to the aircraft, hoist, and RHGSE.

- The Control Station is the user interface of the RHGSE. There are two primary versions of the Hydraulic RHGSE Control Stations that will be covered in this section. They will be referred to as “Configuration 1” (C1) and “Configuration 2” (C2).
 - C1 is used on all Standard configurations of the Hydraulic RHGSE and contains three Digital Displays, toggle switches, and sensor connections. See Figure 22.
 - C2 is used on all CE configurations of the Hydraulic RHGSE and contains three Digital Displays, Voltage Monitor, Extend/Retract Rocker Switch, and Safety System Controls. See Figure 23.
- The three Digital Displays give a visual readout of the **Load** being applied by the RHGSE onto the cable, the **Length** of cable that is currently in the Tub, and the **Speed** at which the hoist is extending/retracting. See Figure 22.
- The Extend/Retract Rocker Switch controls the direction of the Hydraulic Drive System and is used to toggle between extend and retract operations on the RHGSE. The Extend/Down position is used when extending the rescue hoist cable down into the RHGSE. The Retract/Up position is used when retracting the cable back into the hoist.
 - C1 – It is located on at the top of the upright tower. In this configuration, the Extend/Retract Rocker Switch will activate the RHGSE if the safety covers are closed. See Figure 24.
 - C2 – It is located on the front of the Control Station. In this configuration, the Extend/Retract Rocker Switch is used to select operational direction and will only activate the RHGSE if the safety system is armed. See Figure 23.



Figure 22 - Control Station - Digital Displays



Figure 23 - Control Station - User Interface



Figure 24 - Rocker Switch

Document Title		ZGS-10000-X-X Hydraulic Rescue Hoist Ground Support Equipment		
Document No.	Rev	Document Type	Release Date	
ZOM-10000-X	H	Operation & Maintenance Manual	Sept 20, 2022	

4.19 600 lb. Hook Check Point

- The 600 lb. Hook Check Point is provided to complete the necessary hook safety checks required by the hoist OEM Operation and Maintenance Manuals. This offers a quick and easy method of applying a 600 lb. (272.2 kg) load to the rescue hook and ball end of the rescue hoist cable to verify that the hook is attached securely and that the cable is in suitable condition with just one person.
- An eye bolt and nylon tether are attached to the Frame that will produce the load. See Figure 25.



Figure 25 - 600 lb. Hook Check Point

4.20 Hydraulic Tote Kit & Spare Parts

- The Hydraulic Tote Kit is included with all RHGSE configurations and contains the items seen in Figure 26.
- The Cable Reel Adapter is used for installing new spools of cable onto the rescue hoist. It is a multi-use tool for either Breeze or Goodrich style cable spools.
- The Tote Kit includes tools used for general purpose maintenance such as a spring scale, 5/32 T-handle, 7/16 wrench, and a 0-24 in-oz Torque Watch.
- Spare Lubridryer Pads, Tub Plugs, Air Filters, and Fuses are also included.



Figure 26 - Hydraulic Tote Kit

4.21 MagSens System

- The MagSens is a rescue hoist cable inspection device. Coupled with the Standalone system, they can identify defects on any part of the rescue hoist cable. It enables the ability to measure, document, and monitor the condition of the cable throughout its service life.
- If the MagSens was purchased with your RHGSE please refer to the MagSens manual.



Figure 27 - MagSens System

Document Title		ZGS-10000-X-X Hydraulic Rescue Hoist Ground Support Equipment		
Document No.	Rev	Document Type	Release Date	
ZOM-10000-X	H	Operation & Maintenance Manual	Sept 20, 2022	

5 Operation of the RHGSE

5.1 Augmentation Codes

Augmentation Codes indicate an augmentation to the standard operation of the RHGSE. Such as a Water Rinse, use of a MagSens System, or steps that are specific to either a “CE” or “Standard” configuration of the RHGSE.

- (WR): Water Rinse - Steps preceded by “(WR)” should be skipped if a water rinse is not desired.
- (MS): MagSens - Steps preceded by “(MS)” should be skipped if a MagSens is not being employed.
- (CE): CE Specific – Steps Preceded by “(CE)” will only pertain to CE configurations of the RHGSE and can be skipped if a Standard configuration is being used.
- (ST): Standard Specific – Steps Preceded by “(ST)” will only pertain to Standard configurations of the RHGSE and can be skipped if a CE configuration is being used.

5.2 Operation Warnings



Before operation of the RHGSE, thoroughly review the entire manual. Failure to do so could cause injury or cause damage to the aircraft, rescue hoist, or RHGSE.

Never operate the RHGSE with loose clothing, jewelry, ties, long hair, or anything that may become entangled. Failure to do so could cause injury or cause damage to the aircraft, rescue hoist, or RHGSE.

Never actuate the Extend/Retract Rocker Switch unless all prerequisites for running the RHGSE have been satisfied. Components will begin to rotate rapidly, and anything placed on the Tub and Spooler will be ejected. Failure to do so could cause injury or cause damage to the aircraft, rescue hoist, or RHGSE.



Do not exceed 5 mph (8 kph) when towing the RHGSE. Doing so could cause damage to the RHGSE.

The maximum sustained load should not exceed 300 lbs. (136.08kg) for repetitive evolutions. Excessive use of the RHGSE at high loads should be limited without regular in-flight extension of the rescue hoist cable. Failure to relieve the trapped twist via in-flight extension after heavy loading could cause damage to the rescue hoist and RHGSE.

During cable conditioning, do not exceed a maximum load of 300 lbs. (136.08kg) with the RHGSE. The cable should then be relieved by fully extending the cable during in-flight operations and retracted with a maximum load of 200 lbs. (90.71kg). Failure to do so could cause damage to the rescue hoist and RHGSE.

During cable conditioning, do not exceed **three** hoist cycles before relieving the twist from the cable by fully extending the cable during in-flight operations. Failure to do so could cause damage to the rescue hoist and RHGSE.

Document Title		ZGS-10000-X-X Hydraulic Rescue Hoist Ground Support Equipment		
Document No.	Rev	Document Type	Release Date	
ZOM-10000-X	H	Operation & Maintenance Manual	Sept 20, 2022	

5.3 RHGSE Setup



Step 1 - Position the RHGSE.

- Position the RHGSE parallel to the aircraft directly under the rescue hoist's cable exit point with the cable lined up slightly behind the LubriDryer/MagSens cable entry point.



Figure 28 - Positioning the RHGSE

Step 2 - Perform a Slip Clutch Quick-Check.

CAUTION

An improperly adjusted clutch could cause the cable to ride out of the Tub and kink. Always perform a Slip Clutch Quick-Check prior to operation. Failure to do so could cause damage to the hoist and RHGSE.

If the slip clutch is out of range, it needs to be adjusted before operation. Failure to do so could cause damage to the rescue hoist and RHGSE.

- Place the hook of the Spring Scale in the hole on the side of the Tub.
- The static breakaway load should be 2—3 lbs. (.9–1.3 kg). If the Slip Clutch is not within tolerance, do not proceed and move to Appendix C for adjustment procedures.



Figure 29 - Slip Clutch Quick-Check

Step 3 - Open the Oil Shut-off Valve.

CAUTION

Always reference the OEM's recommendation for lubricating the rescue hoist cable. Failure to do so could cause damage to the rescue hoist.

Steps instructing lubrication of the cable should be skipped if they are in contradiction to the OEM's recommendation for lubricating the rescue hoist cable. Failure to do so could cause damage to the rescue hoist.

- Open the Oil Shut-off Valve on the Lubridryer. This allows saturation of the Lubridryer Pads, which will lubricate the rescue hoist cable.

Document Title		ZGS-10000-X-X Hydraulic Rescue Hoist Ground Support Equipment		
Document No.	Rev	Document Type	Release Date	
ZOM-10000-X	H	Operation & Maintenance Manual	Sept 20, 2022	

Step 4 - Power Battery Charger.

⚠ CAUTION

Always confirm that the wall outlet voltage matches the voltage specifications of the Battery Charger prior to hook up. Failure to do so could cause damage to the aircraft, hoist, and RHGSE.

- Connect the RHGSE on-board Battery Charger to an appropriate power source.

NOTE:

LED's will illuminate on the front of the Battery Charger to indicate it is functioning properly.

Step 5 - Enable Power.

⚠ CAUTION

Never Operate the RHGSE or store it with the Battery Select Switch in the “BOTH” or “ALL” positions. Failure to do so could cause damage to the RHGSE.

- Actuate the Battery Select Switch to the appropriate position. See Figure 30.
- Position #1: Enable 24 VDC on-board battery power.
- Position #2: Enable 28 VDC Alternate Power Adapter.



Figure 30 - Battery Select Switch & Alternate Power Adapter

Step 6 - Engage Swivel Locks.

⚠ WARNING

The Swivel Locks should remain locked while the RHGSE is in use. This ensures the caster orientation remains in-line with the RHGSE frame and prevents the RHGSE from shifting towards the airframe. Failure to do so could cause injury or cause damage the aircraft, hoist, and RHGSE.

- To toggle the Swivel Locks, pull and rotate the ring 90 degrees.
- Locked: Horizontal key ring alignment. See Figure 31.
- Un-locked: Vertical key ring alignment.



Figure 31 - Swivel Locks

Step 7 - (WR) Fill the Tub with water.

- Ensure that the yellow tub plug is in the drain hole of the Rotatub.
- Fill the Tub with 10 gal. of fresh water.

Step 8 - Enable Rescue Hoist Power.

- Follow the necessary steps to enable power to the rescue hoist system.



Figure 32 - Fill Tub w/ Fresh Water

Document Title		ZGS-10000-X-X Hydraulic Rescue Hoist Ground Support Equipment		
Document No.	Rev	Document Type	Release Date	
ZOM-10000-X	H	Operation & Maintenance Manual	Sept 20, 2022	

Step 9 - Pay out rescue hoist cable.



Always use care while operating a rescue hoist. Never allow the rescue hoist cable to kink or get dirty. Failure to do so could cause injury or cause damage to the rescue hoist and the RHGSE.

- Operate the rescue hoist pendent in the Extend/Out/Down direction to pay out rescue hoist cable.
 - **Three Groove Capstans:** Pay out a minimum of 20 ft. of rescue hoist cable.
 - **Four Groove Capstans:** Pay out a minimum of 20 ft. of rescue hoist cable.

Step 10 - Stow Hook is Spooler.

- Place the hook in the slot on the Spooler.
- The Hook should be facing down so that the cable is exiting the hook assembly upwards. This allows the twist to be translated down to the swivel bearing. See Figure 33.



Figure 33 - Hook Placement

Step 11 - (MS) Install the MagSens Head.



Use great care when handling the MagSens Head. Failure to do so could cause damage to the MagSens Head.

- Use the (2) thumb screws to attach the MagSens Head to the Upper Weldment. See Figure 34.



Figure 34 - MagSens

Step 12 - (MS) Open the MagSens Head.



Always keep hold of the MagSens Cover when opening the Latch to prevent it from springing open. Failure to do so could cause damage to the MagSens Head.

NOTE:

When opening the MagSens Head, it is recommended to hold the cover with the left hand while the right hand unhooks the latch.

- Unlock the Latch and open the MagSens Head.

Document Title		ZGS-10000-X-X Hydraulic Rescue Hoist Ground Support Equipment		
Document No.	Rev	Document Type	Release Date	
ZOM-10000-X	H	Operation & Maintenance Manual	Sept 20, 2022	

Step 13 - Open the Lubridryer.

- Move the Lubridryer Latch upward and open the Lubridryer.
- Replace dirty Lubridryer Pads with new ones.

Step 14 - Open the Safety Covers.

- Pull the Upright Cover open to free it from the magnet.
- Un-lock the Latch and hinge the Capstan Cover Open.

Step 15 - Place Cable into Lubridryer.

- Install the rescue hoist cable into the Lubridryer.
- Close the cover and lock the Latch. See Figure 35.

Step 16 - Place Cable in MagSens Head.

- Installed the rescue hoist cable into the MagSens Head.
- Close the Cover and lock the Latch. See Figure 36.

Step 17 - Wrap Cable around Capstans.

⚠ CAUTION

Capstans are life and wear limited items. Always ensure the that they meet the specified tolerances dictated by Appendix C. Continued use of Capstans that do not satisfy the tolerance specifications could cause damage to the aircraft, hoist, or RHGSE.

The cable must always be wrapped around the Lower Capstan first. Failure to do so can cause damage to the rescue hoist and RHGSE.

Always ensure the rescue hoist cable is wrapped tightly into the correct groove. Failure to do so can cause damage to the rescue hoist and RHGSE.

- Pull the cable tight and start wrapping it around the innermost groove of the Lower Capstan.
- Continue wrapping the cable to the Upper Capstan's innermost groove, in a counterclockwise rotation.
- Tug on the rescue hoist cable every time it comes over the top of the Capstan to ensure a tight seat.
- Repeat the previous steps on the following grooves of the Capstan until the cable is fully wrapped around the Capstans. See right side of Figure 37.



Figure 37 - Capstan Cable Wrap

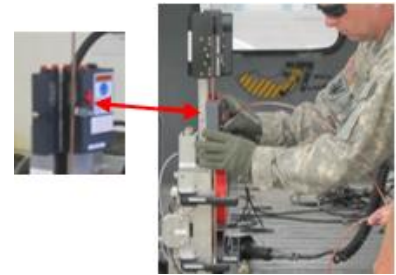



Figure 35 - Cable in Lubridryer



Figure 36 - Cable in MagSens

Document Title		ZGS-10000-X-X Hydraulic Rescue Hoist Ground Support Equipment		
Document No.	Rev	Document Type	Release Date	
ZOM-10000-X	H	Operation & Maintenance Manual	Sept 20, 2022	

Step 18 - Engage Exit & Pressure Rollers.

⚠ CAUTION

Ensure the rescue hoist cable is secured by the Exit and Pressure Rollers. Failure to do so can cause damage to the rescue hoist and RHGSE.

- Pull the Exit & Pressure Roller assemblies outward and remove the quick release pin.
- Ensure the cable is tight underneath the Rollers.
- Stow the pin in the disengaged position. See Figure 38.

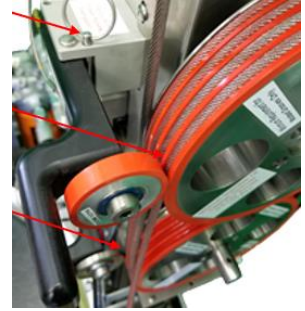

Figure 38 - Exit & Pressure Rollers

Step 19 - Close the Safety Covers.

NOTE:

The Safety Covers must be shut to satisfy the RHGSE Safety Circuit.

- Close the Capstan Cover and lock the Latch.
- Close the Upright Cover and ensure it is secured with the magnet.



Figure 39 - Close Safety Covers

Step 20 - Route Cable through Guide Rollers.

- Lift the hook out of the top of the Spooler.
- Route the remaining cable down and through the guide rollers.
- Place the cable to the right of the Small Guide Roller and to the left of the Large Guide Roller.
- The cable should go underneath the Large Guide Roller and fall into the slot between the Tub and Spooler.



Figure 40 - Guide Wheel Cable Routing

Document Title		ZGS-10000-X-X Hydraulic Rescue Hoist Ground Support Equipment		
Document No.	Rev	Document Type	Release Date	
ZOM-10000-X	H	Operation & Maintenance Manual	Sept 20, 2022	

Step 21 - Route Cable into Spooler.

⚠ CAUTION

Always Check that the cable is sitting flush to the bottom of the Spooler Slot. If it is not, the cable will not start wrapping at the bottom of the Spooler and there may not be enough space for the cable to wrap properly around the Spooler. If this occurs, the cable may come out of the Spooler and Rotatub, the operator **MUST STOP IMMEDIATELY**. Improper set up and operation could cause damage to the rescue hoist and RHGSE.

Do not allow the rescue hoist cable to loop out of the Spooler once the Hook is seated. Failure to do so could cause damage to the rescue hoist and RHGSE.

Always allow a minimum of 3 ft. of excess cable to be stored inside the Spooler. Failure to do so could cause damage to the rescue hoist and RHGSE.

- Wrap the excess rescue hoist cable clockwise around the base of the Spooler. See Figure 41.
- Route the remainder of the cable through the slot and into the Spooler. Ensure the cable sits comfortably in the bottom of the slot. See Figure 42.
- Place the Hook on its side in the slot on top of the spooler to prevent it from sliding around during operation. See Figure 43.
- (WR) Place the Hook inside the Spooler to fully submerge it.
- Check to ensure the Cable is still properly routed through the Guide Rollers.



Figure 41 - Cable Routing



Figure 42 - Spooler Slot



Figure 43 - Hook Placement

NOTE:

IF the length of cable is insufficient to achieve a minimum of 3 ft. of excess cable inside the Spooler with the Spooler Slot at the 3 O'clock position, then the rescue hoist cable should be removed from the RHGSE. Pay out more cable and re-wrap the cable until a minimum of 3 ft. of cable is inside the Spooler.

Step 22 - (MS) Setup MagSens Standalone.

- Refer to the operations manual or quick start guide for the MagSens to set up the test

Step 23 - (ST) Enable Digital Display Power.

- Toggle the Control Station Power Switch to turn on power to the Digital Displays. Control Stations on previous RHGSE configurations needs to be powered separately. See Figure 44.
- The Digital Displays should power up and self-test.



Figure 44 - Digital Display Power Switch

Document Title		ZGS-10000-X-X Hydraulic Rescue Hoist Ground Support Equipment		
Document No.	Rev	Document Type	Release Date	
ZOM-10000-X	H	Operation & Maintenance Manual	Sept 20, 2022	

Step 24 - TARE the Load Display

- Press the “TARE” button on the front of the Load Digital Display to set the load to zero.

5.4 Extending Operation.

Step 1 - (CE) Enable RHGSE.

⚠ CAUTION

Always ensure the Extend/Retract Rocker Switch is in the neutral (middle) position before powering the Drive System of the RHGSE. Failure to do so could cause damage to the RHGSE and any items stored atop the Tub and Spooler.

- Press the “Start/Reset” button on the front of the Control Station to test the Safety Circuit and if satisfied, power the drive system.

NOTE:

The Red Light labeled “Ready” should illuminate. This indicates the Circuit has passed and the RHGSE is ready for operation.

Step 2 - Enable RHGSE Extend.

⚠ CAUTION

Always ensure the Extend/Retract Rocker Switch is in the neutral (middle) position before powering the Drive System of the RHGSE. Failure to do so could cause damage to the RHGSE and any items stored atop the Tub and Spooler.

NOTE:

All Safety Covers must be closed, and all E-Stops must be disengaged to power the RHGSE.

- Actuate the Extend/Retract Rocker Switch to the “EXTEND (DOWN)” position.

NOTE:

The Green Light labeled “Extending” should illuminate and the rescue hoist cable should become taught as the RHGSE begins to generate a load of approximately 100 lbs. this indicates that the RHGSE is ready to generate a load for the extend hoisting operation.

Step 3 - Extend Rescue Hoist Cable.

⚠ CAUTION

If the cable snags, loosens, unwraps, or becomes free from RHGSE in any way, be prepared to stop immediately. Failure to do so could result in damage to the aircraft, rescue hoist, and RHGSE.

If the Cable begins to loosen on the capstans at any point, stop operation and re-seat the cable into the Capstan Grooves before continuing. Failure to do so could result in damage to the aircraft, rescue hoist, and RHGSE.

When extending to the rescue hoist “full out” position, ensure that the limit switch is functioning and stops the hoist. Failure to do so could result in damage to the aircraft, rescue hoist, and RHGSE.

- Actuate the Rescue Hoist Pendant in the extend/down/out direction at approx. 50 ft/min. and carefully watch the capstans to ensure the cable does not become loose.
- Increase Speed to approx. 100 ft/min. and continue extending until the full out limit switch is tripped.
- Slow the hoist as the cable approaches the full out position and observe the cable.

Document Title		ZGS-10000-X-X Hydraulic Rescue Hoist Ground Support Equipment		
Document No.	Rev	Document Type	Release Date	
ZOM-10000-X	H	Operation & Maintenance Manual	Sept 20, 2022	

Step 4 - Disable RHGSE Extend.

- Actuate the Extend/Retract Rocker Switch to the OFF (center) position to cease operation of the RHGSE.

5.5 Retracting Operation.

⚠ CAUTION

Any cable remaining above the Tub will not be cleaned by the RHGSE during a water rinse operation. Care should be taken to rinse remaining length of cable that runs up through the RHGSE and onto the last few turns of the rescue hoist drum. Failure to do so could cause damage to the rescue hoist.

Step 1 - (WR) Change Lubridryer Pads.

- Unlock the Latch and open the Lubridryer.
- Change the Lubridryer pads and soak them with the same lubricating oil used inside the Lubridryer.
- Close and Lock the Lubridryer with the rescue hoist cable inside.

Step 2 - (WR) Enable Lubridryer Oiler.

- Open the Lubridryer Oil Shut-off Valve. Turn it counterclockwise 3 times.

Step 3 - (WR) Enable Air Compressor.

- Actuate the “Compressor” switch on the front of the Control Station to turn on the air compressor.

Step 4 - Enable RHGSE Retract.

- Activate the Extend/Retract Rocker Switch to the “RETRACT (UP)” Position.

NOTE:

All Safety Covers must be closed, and all E-Stops must be disengaged to power the RHGSE.

The Orange Light labeled “Retracting” should illuminate. This indicates that the RHGSE is ready to generate a load for the retract hoisting operation.

Step 5 - Confirm Load Adjustment.

⚠ WARNING

To avoid accidentally lifting the RHGSE off the ground, ALWAYS ensure the Retract Load Adjustment knob is set to a load lesser than 600 lbs. Failure to do so could cause injury, and cause damage to the aircraft, rescue hoist, and RHGSE.

To avoid accidentally lifting the RHGSE off the ground, NEVER actuate the rescue hoist pendant in the Retract/Up/In direction with the Extend/Retract Rocker Switch in the “Extend” position. Failure to do so could cause injury, or damage the aircraft, rescue hoist, and RHGSE.

NOTE:

It is necessary to confirm that the load being generated by the RHGSE is within safe parameters prior to manual adjustment of the Retract Load Adjustment knob. This is a safety precaution to ensure the RHGSE does not unexpectedly lift from the ground with a technician between the RHGSE and the aircraft.

Document Title		ZGS-10000-X-X Hydraulic Rescue Hoist Ground Support Equipment		
Document No.	Rev	Document Type	Release Date	
ZOM-10000-X	H	Operation & Maintenance Manual	Sept 20, 2022	

- With one foot on the RHGSE Ballast Bar, **SLOWLY** begin retracting the rescue hoist. If the Load Meter rises above 600 lbs. or the RHGSE begins to lift from the ground in any way, cease hoisting operation immediately.
- If an unsafe load was measured, or the RHGSE lifted from the ground, then turn the Retract Load Adjustment knob counterclockwise 3 FULL turns and repeat the test.
- If a safe load is measured and the RHGSE does not lift from the ground, then proceed to the next step.

Step 6 - Adjust Retract Load.



To avoid accidentally lifting the RHGSE off the ground, do not exceed loads of 600 lbs. Doing so could cause injury, or cause damage to the aircraft, rescue hoist, and RHGSE.

To avoid accidentally lifting the RHGSE off the ground, NEVER turn the Retract Load Adjustment knob while retracting at speeds lower than 30 ft/min. Doing so could cause injury, or cause damage to the aircraft, rescue hoist, and RHGSE.

NOTE:

One revolution of the Retract Load Adjustment knob is equivalent to approximately 100 lbs. of load.

The only time a load as high as 600lb. (272.2kg) is required is when conditioning a cable after it has been installed. The minimum speed required to get to 600lb. (272.2kg) is about 100fpm. (30mpm).

Water rinse loads should be limited to 100 lbs.

- Actuate the Rescue Hoist Pendant in the Retract/Up/In direction at approximately 30 ft/min. while manually adjusting the Retract Load Adjustment knob until the desired retracting load is achieved.
- To increase the load, turn the knob counterclockwise. See Figure 45.



Figure 45 - Load Adjustment

Step 7 - Retract Rescue Hoist Cable.



To avoid fouling the rescue hoist, always observe the wrapping of the cable on the rescue hoist drum during RHGSE operation. Failure to do so could cause damage to the aircraft, rescue hoist, and RHGSE.

- Once the retract load is set, increase the hoist speed to approximately 100 ft/min.
- Slow the hoist to approximately 30 ft/min when there is only 20 ft. of cable remaining in the Tub

Document Title		ZGS-10000-X-X Hydraulic Rescue Hoist Ground Support Equipment		
Document No.	Rev	Document Type	Release Date	
ZOM-10000-X	H	Operation & Maintenance Manual	Sept 20, 2022	

Step 8 - Pause Hoisting Operation and Remove Cable.

⚠ CAUTION

Always pay close attention to the remaining length of rescue hoist cable inside the tub. Be prepared to stop hoisting operations if the cable or hook exits the Tub and Spooler or if the Length Alarm sounds. Failure to do so could cause damage to the aircraft, rescue hoist, and RHGSE.

The Length display is for reference only. Operators should rely on visual inspection of the cable inside the Tub when operating the RHGSE with less than 20 ft. of rescue hoist cable remaining. Failure to do so could cause damage to the aircraft, rescue hoist, and RHGSE.

NOTE:

The value displayed by the Length Meter is not exact and should be used for REFERENCE ONLY. The value is representative of how far the Capstans have turned and does not take slippage into account. The Capstans are not a perfect friction device and slippage can vary depending on Capstan wear, cable lubricity and Load.

The Control station is equipped with a Siren that will begin to sound if the Length Display travels to a negative value.

- Stop hoisting operations when the last wrap of cable is visible in the bottom of the Tub, or the Length Display approaches Zero.

NOTE:

The end of the cable entering the Spooler slot should be visible with no remaining cable wraps on top of it.

Step 9 - Disable RHGSE Retract.

- Actuate the Extend/Retract Rocker Switch to the OFF (center) position.

Step 10 - (Optional) Perform Additional Cycle.

- IF additional hoist cycles are required, move to Step 2 - on page 28.

Step 11 - Remove Cable from Spooler.

- Lift the hook and cable out of the Tub and Spooler and place the hook into the top slot of the Spooler so the cable is exiting the hook assembly in an upwards manor. See Figure 46.

Step 12 - Remove Cable from Guide Rollers.

- Slowly rotate the Spooler until the rescue hoist cable passes underneath the Large Guide Roller and remove the cable.

Step 13 - Open Safety Covers.

- Pull the Upright Cover open to disengage the magnet.
- Unlock the Latch and open the Capstan Cover.

Step 14 - Disengage Exit and Pressure Roller

- Pull the Pressure Roller assembly back and pin it in the open position using the quick release pin.
- Pull the Exit Roller assembly back and pin it in the open position using the quick release pin.



Figure 46 - Cable Removal

Document Title		ZGS-10000-X-X Hydraulic Rescue Hoist Ground Support Equipment		
Document No.	Rev	Document Type	Release Date	
ZOM-10000-X	H	Operation & Maintenance Manual	Sept 20, 2022	

Step 15 - Unwrap Cable from Capstans.



Keep the rescue hoist cable in front of the RHGSE and never allow it to become kinked or entangled. Doing so Could cause injury or damage to the aircraft, rescue hoist, and RHGSE.

- Gently remove the rescue hoist cable from the Capstans. Start by un-raveling the cable from the outer most grooves first, and then work inward. Be mindful of cable management.
- Allow any kinks or twists in the cable to translate down the hook swivel.

Step 16 - Retract Remaining Cable.



Do not operate the rescue hoist with less than 2 feet of cable remaining between the LubriDryer and the hook. Failure to do so could cause damage to the aircraft, rescue hoist, and RHGSE.

- Slowly actuate the rescue hoist pendent in the Retract/In/Up direction until the hook is about to lift from the Spooler and then STOP. See Figure 47.
- Manually pull the remaining cable through the Lubridryer until the hook touches the bottom of the Lubridryer.



Figure 47 - Manual Retraction Point

Step 17 - Open the Lubridryer.

- Unlock the Latch and open the Lubridryer.
- Remove the rescue hoist cable from the Lubridryer.

Step 18 - (MS) Finish MagSens Reading.

- Manually and carefully pull the remainder of cable through MagSens Head until the hook touches the bottom of the MagSens Head. See Figure 48.

Step 19 - (MS) Open MagSens.



Always keep hold of the MagSens Cover when opening the Latch to prevent it from springing open. Failure to do so could cause damage to the MagSens Head.

- Keeping a hand one hand on the MagSens body, carefully unlock the Latch and open the MagSens.
- Remove the rescue hoist cable from the MagSens.

Step 20 - (WR) Turn Off Compressor

- Actuate the “Compressor” toggle switch on the front of the control station to the OFF position to disable power to the Air Compressor.

Step 21 - Inspect Ball End.

- Visually inspect the cable just above the ball end to ensure no broken wires are visible.



Figure 48 - Manual Retraction

Document Title		ZGS-10000-X-X Hydraulic Rescue Hoist Ground Support Equipment		
Document No.	Rev	Document Type	Release Date	
ZOM-10000-X	H	Operation & Maintenance Manual	Sept 20, 2022	

Step 22 - Fully Retract Cable.

- Actuate the rescue hoist pendent in the Retract/Up/In direction until the hook is seated against the mouth of the rescue hoist. See Figure 49.

Step 23 - (MS) Close MagSens Head.

- Close the MagSens Head and lock the Latch.

Step 24 - Close Safety Covers

- Close the Capstan Cover and Lock the Latch
- Close the Upright Cover until the Magnet retains it.

Step 25 - (WR) Drain Tub.

- Position the RHGSE over a suitable drain area.
- Reach into the Spooler and locate the yellow Tub Plug.
- Position the Tub Plug over the slot in the RHGSE Frame.
- Remove the Tub Plug and let drain.
- Wipe off the RHGSE with a soft rag to remove any standing water or blow the water off with 30psi shop air.



Figure 49 - Cable Retraction

Step 26 - Refresh Lubridryer

- Replace the dirty Lubridryer Pads with fresh ones.
- Disable the Oiler by turning the Oil Shut-off Valve clockwise approx. 3 times or until it is hand tight.
- Close the Lubridryer and lock the Latch.

Step 27 - (MS) Save MagSens Data.

Step 28 - (MS) Remove MagSens.

⚠ CAUTION

Use great care when handling the MagSens Head. Failure to do so could cause damage to the MagSens Head.

- Carefully remove the thumb screws and remove the MagSens from the RHGSE.
- Stow the MagSens in its designated case.

Step 29 - Disable Control Station Power.

- Actuate the Battery Select Switch to the OFF position.
- (ST) Actuate the “Power” toggle switch on the front of the control station to the OFF position to disable power to the Digital Displays.

Step 30 - Disable Aircraft Hoist Power

- Follow the necessary steps to disable power to the rescue hoist system.

Document Title		ZGS-10000-X-X Hydraulic Rescue Hoist Ground Support Equipment		
Document No.	Rev	Document Type	Release Date	
ZOM-10000-X	H	Operation & Maintenance Manual	Sept 20, 2022	

5.6 600 lb. Hook Check.

Step 1 - Position RHGSE

- Position the RHGSE so the Lifting Eyelet that is connected to the yellow Nylon Tether is directly underneath the rescue hoist hook.
- Enable the Swivel Locks and Caster Brakes to prevent the RHGSE from moving once in place.

Step 2 - Enable Rescue Hoist Power.

- Follow the necessary steps to enable power to the rescue hoist system.

Step 3 - Extend Rescue Hoist Cable.

- Actuate the rescue hoist pendent in the Extend/Down/Out direction and pay out approximately 10 ft. of rescue hoist cable.

Step 4 - Inspect Ball and Hook.

- Thoroughly inspect the ball end of the cable to ensure it is in good condition with no loos or broken wires.
- Perform an inspection of the hook to verify proper installation and assembly prior to applying a load.

Step 5 - Attach Hook to Tether.

- Attach the rescue hoist hook to the yellow Nylon Tether.
- Lock the hook.



Figure 50 - 600lb. Hook Check Setup

Step 6 - Remove the Slack



Never touch a cable that is under tension. Failure to do so could cause injury.

Never apply a load to a hook that has not been visually inspected for proper assembly. Failure to do so could cause injury or cause damage to the aircraft, rescue hoist, and RHGSE.

- **SLOWLY** operate the rescue hoist in the Retract/Up/In direction to removing the slack from the rescue hoist cable and the yellow Nylon Tether. See Figure 51.
- Remove hands from the cable and Tether once the slack is removed.



Figure 51 - Remove Slack

Document Title		ZGS-10000-X-X Hydraulic Rescue Hoist Ground Support Equipment		
Document No.	Rev	Document Type	Release Date	
ZOM-10000-X	H	Operation & Maintenance Manual	Sept 20, 2022	

Step 7 - Apply 600 lb. Load



Never place any body parts between the RHGSE and the ground when it is raised from the ground. Doing so could cause injury.



Do not allow the RHGSE to swing towards the aircraft when lifting it. Doing so could cause damage to the aircraft, hoist and RHGSE.



Figure 52 - 600 lb. Hook Check

NOTE:

There will be a 600lb. (272.2kg) load on the hook and cable end with the front inboard caster wheel raised only. The other 3 caster wheels must stay on the ground.

- Place one hand on the tow handle and apply a positive pressure away from the aircraft to ensure the RHGSE does not swing towards the aircraft when lifted.
- **SLOWLY** and precisely actuate the rescue hoist pendent in the Retract/Up/In direction to slightly tilt the RHGSE to one side.
- Lift only the inboard (tower side) wheels approximately 1/2" from the ground to achieve 600 lbs. of load on the hook. See Figure 52.

Step 8 - Lower RHGSE.

- **SLOWLY** actuate the rescue hoist pendent in the Extend/Down/Out direction to lower the RHGSE.
- Once it contacts the ground, pay out an additional 2-3 ft. of cable.

Step 9 - Detach Hook from Tether.

- Unlock the Hook
- Detach the rescue hoist hook from the yellow Nylon Tether.
- Stow the Nylon Tether using the retention bungee.



Figure 54 - Detach Hook



Figure 53 - Stow Hook

Step 10 - Fully Retract Cable.

- Actuate the rescue hoist pendent in the Retract/Up/In direction until the hook is seated against the mouth of the rescue hoist.

Step 11 - Disable Aircraft Hoist Power.

- Follow the necessary steps to disable power to the rescue hoist system.

Document Title		ZGS-10000-X-X Hydraulic Rescue Hoist Ground Support Equipment		
Document No.	Rev	Document Type	Release Date	
ZOM-10000-X	H	Operation & Maintenance Manual	Sept 20, 2022	

5.7 Rescue Hoist Cable Removal.

The RHGSE can be utilized to assist in the removal of a cable from the rescue hoist.

Step 1 - Extend Operation.

- Follow the “Extend Operation” instructions of Section **Error! Reference source not found.**
- Return to here once the rescue hoist is fully extended and at the full out limit switch.

Step 2 - Bypass Full Out

CAUTION

Always reference the OEM’s procedures for maintenance and operation of the rescue hoist. Failure to do so could cause damage to the rescue hoist.

- Bypass the full out limit switch on the rescue hoist as directed in the OEM manual.

Step 3 - Extend the hoist.

WARNING

Always use care while operating a rescue hoist. Never allow the rescue hoist cable to kink or get dirty. Failure to do so could cause injury or cause damage to the rescue hoist and the RHGSE.

- Operate the rescue hoist in the Extend/Down/Out direction until the rescue hoist cable can be removed.

Step 4 - Remove Rescue Hoist Cable.

- Remove the rescue hoist cable from the hoist and let the remaining cable lay in front of the RHGSE.

Step 5 - Remove Cable from Capstans.

- Unlock the Latch and Open the Safety Covers.
- Pin the Exit and Pressure Rollers to the open position.
- Carefully unwrap the cable from the Capstans.

Step 6 - Wrap Remaining Cable.

- Manually turn the Tub clockwise to wrap the remaining rescue hoist cable onto the Spooler.

Step 7 - Remove the Tub and Spooler.

- Locate the (4) ¼-20 Lock Nuts and Flat Washers used to fasten the Tub to the Slip Clutch.
- Use a 7/16” Wrench to remove the fasteners.
- Lift up on the bottom of the Tub and remove it from the RHGSE.

Step 8 - Remove Cable from Tub.

- Pull upward on the Spooler and grab the spool of cable.
- Slide the cable up and off the Spooler.

Step 9 - Reinstall Tub and Spooler.

- Re-install the Tub and Spooler onto the Platen Plate studs.
- Install the (4) ¼-20 Lock Nuts and Flat Washers used for fastening the Tub to the Platen Plate.
- Use a 7/16” wrench to tighten the fasteners. Torque to 55 in-lbs.

Document Title		ZGS-10000-X-X Hydraulic Rescue Hoist Ground Support Equipment		
Document No.	Rev	Document Type	Release Date	
ZOM-10000-X	H	Operation & Maintenance Manual	Sept 20, 2022	

5.8 Rescue Hoist Cable Installation.

The RHGSE can be utilized to assist in the installation of a new cable onto the rescue hoist.

Step 1 - Install Cable Reel Adapter.

- Install the Cable Reel Adapter onto the lower Capstan Shaft. See Figure 55.
- Pin the Cable Reel Adapter in place using the attached quick release pin.



Figure 55 - Lower Capstan Shaft

Step 2 - Prepare Cable Reel Adapter

NOTE:

The Cable Reel Adapter is designed to be used with Breeze and Goodrich style cable reels.

- Remove the Torque Nut from the assembly.
- Remove the Spring Clutch from the assembly.
- Choose configuration according to cable spool style:
 - Breeze: Leave Breeze Adapter Sleeve installed. See Figure 57.
 - Goodrich: Remove the Breeze Adapter Sleeve. See Figure 58.



Figure 56 - Goodrich Adapter & Breeze Adapter Sleeve



Figure 57 - Breeze Configuration



Figure 58 - Goodrich Configuration

Step 3 - Install Cable Reel

- Slide cable reel onto the shaft of the Cable Reel Adapter in the correct orientation.
- Install the Spring Clutch onto the assembly with the smooth side facing the cable reel.
- Install the Torque Nut onto the assembly and hand tighten it.



Figure 59 - Spooler Installation

Document Title		ZGS-10000-X-X Hydraulic Rescue Hoist Ground Support Equipment		
Document No.	Rev	Document Type	Release Date	
ZOM-10000-X	H	Operation & Maintenance Manual	Sept 20, 2022	

Step 4 - Install Cable onto Rescue Hoist.

⚠ CAUTION

Always reference the OEM's procedures for maintenance and operation of the rescue hoist. Failure to do so could cause damage to the rescue hoist.

- Follow the OEM's instructions and best-known practices for attaching the cable to the rescue hoist drum.
- Tighten the Torque Nut to apply more pressure to the cable reel if it begins to unspool at any point.

Step 5 - Remove Empty Cable Reel.

- Remove the Torque Nut from the assembly.
- Remove Spring Clutch from the assembly.

Step 6 - Reassemble Cable Reel Adapter.

- Reinstall the Breeze Adapter Sleeve onto the assembly if it was removed.
- Reinstall the Spring Clutch onto the assembly.
- Install the torque Nut onto the assembly and hand tighten it.

Step 7 - Remove the Cable Reel Adapter.

- Unpin the Cable Reel Adapter from the Lower Capstan Shaft.
- Remove the Cable Reel Adapter from the RHGSE and store it in the Tote Kit.

Step 8 - Condition Rescue Hoist Cable.

⚠ CAUTION

During cable conditioning, do not exceed a maximum load of 300 lbs. (136.08kg) with the RHGSE. The cable should then be relieved by fully extending the cable during in-flight operations and retracted with a maximum load of 200 lbs. (90.71kg). Failure to do so could cause damage to the rescue hoist and RHGSE.

During cable conditioning, do not exceed **three** hoist cycles before relieving the twist from the cable by fully extending the cable during in-flight operations. Failure to do so could cause damage to the rescue hoist and RHGSE.

Do not exceed 100 fpm with the rescue hoist during cable condition with the RHGSE. Doing so could cause damage to the rescue hoist and RHGSE.

- Follow the "Extending Operation" and "Retracting Operations" instructions beginning in Section **Error! Reference source not found.** on page **Error! Bookmark not defined.**
- Perform three separate cycles:
 - Cycle 1: Hoist speed 100 fpm. | Extend Load 100 lbs. | Retract Load 100 lbs.
 - Cycle 2: Hoist speed 100 fpm. | Extend Load 100 lbs. | Retract Load 200 lbs.
 - Cycle 3: Hoist speed 100 fpm. | Extend Load 100 lbs. | Retract Load 300 lbs.

Step 9 - Full In-flight Extension.

- During the next flight, extend the cable to full extension and retract an approximate load of 200 lbs. Refer to Appendix C Hydraulic Maintenance for detailed maintenance procedures.

Document Title		ZGS-10000-X-X Hydraulic Rescue Hoist Ground Support Equipment		
Document No.	Rev	Document Type	Release Date	
ZOM-10000-X	H	Operation & Maintenance Manual	Sept 20, 2022	

6 Maintenance Tasks

See Appendix C for all maintenance instructions.

The table below lists required maintenance tasks, their frequency and location within Appendix C.

- Task Levels are broken into 4 categories:
 - **Level 1** – L1 tasks MUST be performed prior to operation of the RHGSE to ensure it is operating within functional parameters before attaching the rescue hoist to it.
 - **Level 2** – L2 tasks should be performed during/after operation of the RHGSE to ensure it remains in peak condition for optimal service life.
 - **Level 3** – L3 tasks are proactive maintenance tasks and should be performed at a fixed rate to ensure the RHGSE remains in peak condition for optimal service life.
 - **Level 4** – L4 tasks are reactive maintenance tasks and should be performed as required by a loss in performance or functionality.
- The frequency listed is the recommended minimum. Certain tasks may need to be performed at higher frequency dependent on usage.

Level	Task	Frequency	Section #
L1 – 1	Visual Inspection	Per Use	C.3.1
L1 – 2	Slip Clutch Quick-Check	Per Use	C.3.2
L1 – 3	Check Battery Voltage	Per Use	C.3.3
L1 – 4	Check Electrical Connections	Per Use	C.3.4
L1 – 5	Change Lubridryer Pads	Per Use / Cycle	C.3.5
L2 – 1	Check Hydraulic Filter Indicator	Per Use	C.3.6
L2 – 2	Clean RHGSE	Per Use	C.3.7
L2 – 3	Stow All Components	Per Use	C.3.8
L2 – 4	Proper Storage	Per Use	C.3.9
L3 – 1	Lubricate Drive Chain	Monthly	C.3.10
L3 – 2	Measure Capstans	Monthly / On Condition	C.3.11
L3 – 3	Grease Swivel Casters	Annually	C.3.12
L3 – 4	Check Load Display Scaling	Annually	C.3.13
L3 – 5	Perform MagSens NiDAQ Check	Annually	C.3.14
L4 – 1	Rotatub Clutch Adjustment	On Condition	C.3.15
L4 – 2	Replace Fuses	On Condition	C.3.16 - C.3.19
L4 – 3	Replace Hydraulic Filter	On Condition	C.3.6
L4 – 4	Replace Batteries	5 Years / On Condition	C.3.20
L4 – 5	Replace Capstans	7 Years / On Condition	C.3.21
L4 – 6	Replace Exit Roller	7 Years / On Condition	C.3.21

Figure 60 - Maintenance Tasks Reference Table

Document Title		ZGS-10000-X-X Hydraulic Rescue Hoist Ground Support Equipment		
Document No.	Rev	Document Type	Release Date	
ZOM-10000-X	H	Operation & Maintenance Manual	Sept 20, 2022	

7 Illustrated Parts Breakdown

ZGS-10000-5-1

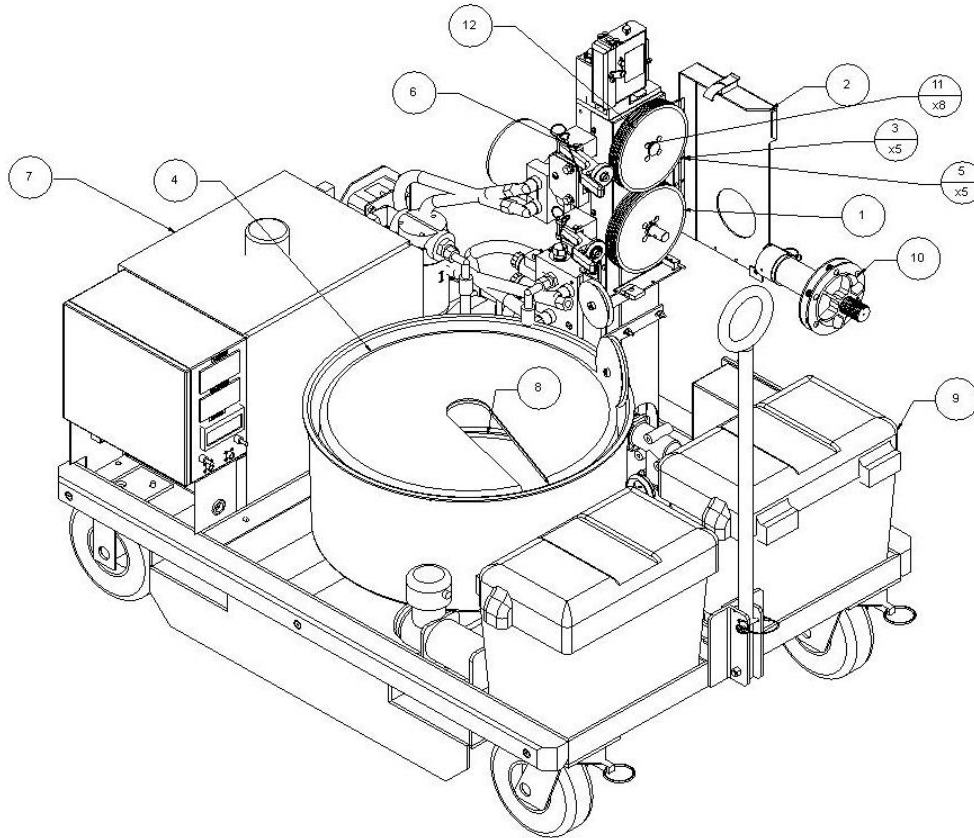

ZGS-10000-5-1

Item	QTY	Part Number	Part Name	Revision
1	1	ZGS-12474-1	Capstan Lower 4.5 mm cable	D
2	1	ZGS-10328-4	Capstan Cover Assy Magnetic Latched	
3	5	1345	8 32 x .38	
4	1	ZGS-10357-2	Spooler Assembly	A
5	5	2551	8-32 nut	
6	1	ZGS-10129-1	Tensioner assy upper Open	
7	1	Mil-H-83282	10 gallons oil	
8	1	ZGS-10149-1	Tub Plug	A
9	1	ZGS-10786-1	Battery and Wiring Subassembly	
10	1	ZGS-10794-1	Cable Reel Adapter Assembly	B
11	8	15082	10-32 x 1.5 SHCS	
12	1	ZGS-12474-2	Capstan Upper 4.5 mm cable	D

Document Title		ZGS-10000-X-X Hydraulic Rescue Hoist Ground Support Equipment		
Document No.	Rev	Document Type	Release Date	
ZOM-10000-X	H	Operation & Maintenance Manual	Sept 20, 2022	

ZGS-10000-5-5

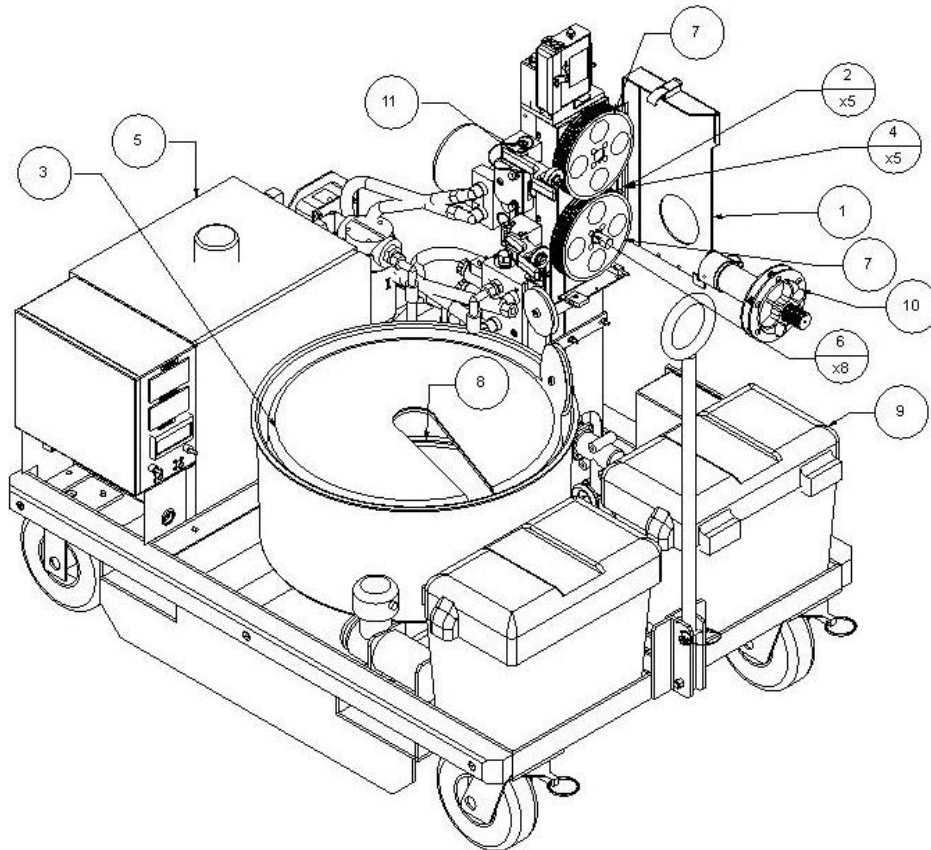

ZGS-10000-5-5

Item	Qty	Part Number	Part Name	Revision
1	1	ZGS-10328-4	Capstan Cover Assy Magnetic Latched	
2	5	1345	8 32 x .38	
3	1	ZGS-10357-2	Spooler Assembly	A
4	5	2551	8-32 nut	
5	1	Mil-H-83282	10 gallons oil	
6	8	5019	10-32 x 1.25 SHCS	
7	2	ZGS-10506-1	Compound Capstan 4 grooves	E
8	1	ZGS-10149-1	Tub Plug	A
9	1	ZGS-10786-1	Battery and Wiring Subassembly	
10	1	ZGS-10794-1	Cable Reel Adapter Assembly	B
11	1	ZGS-10628-1	Tensioner assy upper 4 Groove Roller	

Document Title		ZGS-10000-X-X Hydraulic Rescue Hoist Ground Support Equipment		
Document No.	Rev	Document Type	Release Date	
ZOM-10000-X	H	Operation & Maintenance Manual	Sept 20, 2022	

ZGS-10000-10-1

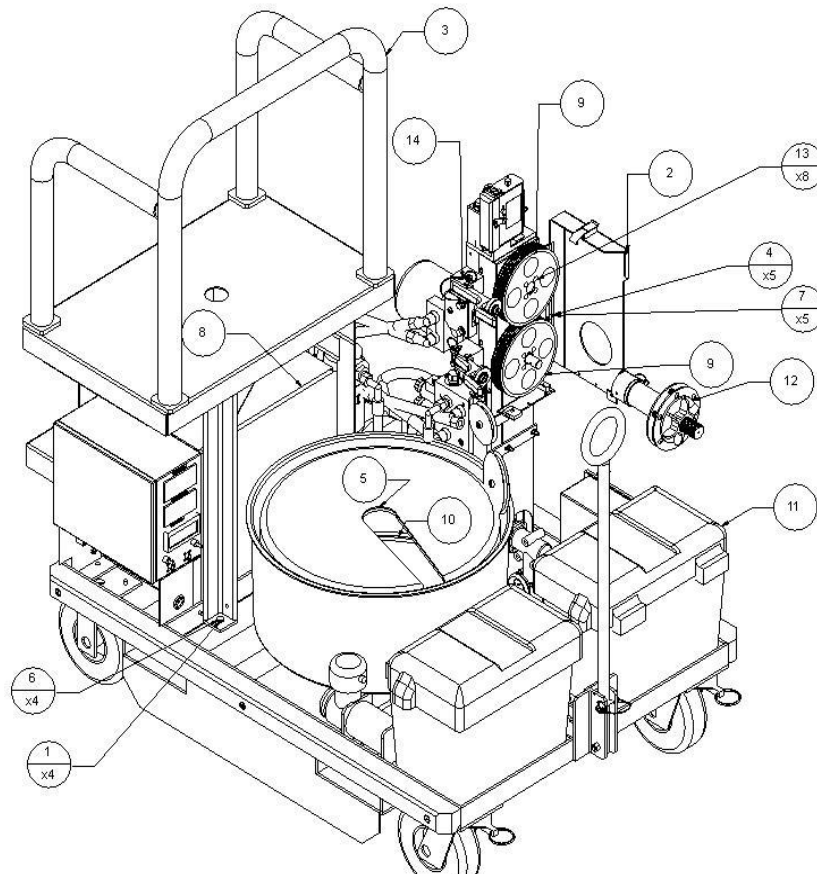

ZGS-10000-10-1

Item	Qty	Part Number	Part Name	Revision
1	4	2556	.38 locknut	
2	1	ZGS-10328-4	Capstan Cover Assy Magnetic Latched	
3	1	ZGS-10457-1	Work Platform	A
4	5	1345	8 32 x .38	
5	1	ZGS-10357-2	Spooler Assembly	A
6	4	3/8 x 1 inch Hex Bolt	3-8 Bolt 1 inch long	
7	5	2551	8-32 nut	
8	1	Mil-H-83282	10 gallons oil	
9	2	ZGS-10506-1	Compound Capstan 4 grooves	E
10	1	ZGS-10149-1	Tub Plug	A
11	1	ZGS-10786-1	Battery and Wiring Subassembly	
12	1	ZGS-10794-1	Cable Reel Adapter Assembly	B
13	8	15082	10-32 x 1.5 SHCS	
14	1	ZGS-10628-1	Tensioner assy upper 4 Groove Roller	

Document Title		ZGS-10000-X-X Hydraulic Rescue Hoist Ground Support Equipment		
Document No.	Rev	Document Type	Release Date	
ZOM-10000-X	H	Operation & Maintenance Manual	Sept 20, 2022	

ZGS-10000-10-1-G-CE

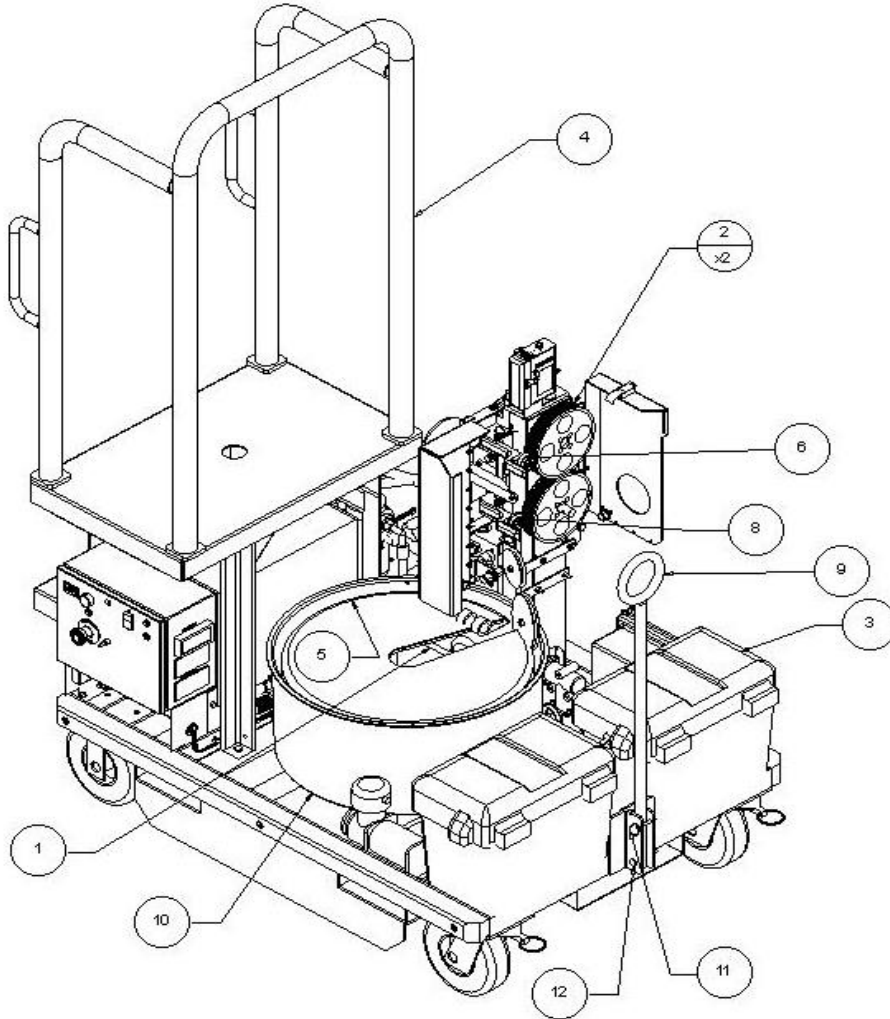

Item	Qty	Part Number	Part Name	Rev
1	1	ZGS-10934-1	Hyd Tote Kit	
2	2	ZGS-10892-1	Compound Capstan .185 4 grooves	A
3	1	ZGS-10786-4	Battery and Wiring Subassembly CE	
4	1	ZGS-10457-2	Work Platform Higher Railing	
5	1	ZGS-10357-1	Spooler Basic	A
6	1	ZGS-10294-1	Exit Roller Assy	B
7	4	ZGS-10149-1	Tub Plug	A
8	1	ZGS-10127-1	Pressure Roller Assy	B
9	1	ZGS-10111-1	Tow Handle	
10	1	ZGS-10022-1	Tub , GSE	C
11	1	FPC4-15R	Tow Handle Retaining QRP	
12	1	163	3-8 Bolt 2.5 inch long	

Document Title		ZGS-10000-X-X Hydraulic Rescue Hoist Ground Support Equipment		
Document No.	Rev	Document Type	Release Date	
ZOM-10000-X	H	Operation & Maintenance Manual	Sept 20, 2022	

ZGS-10786-1

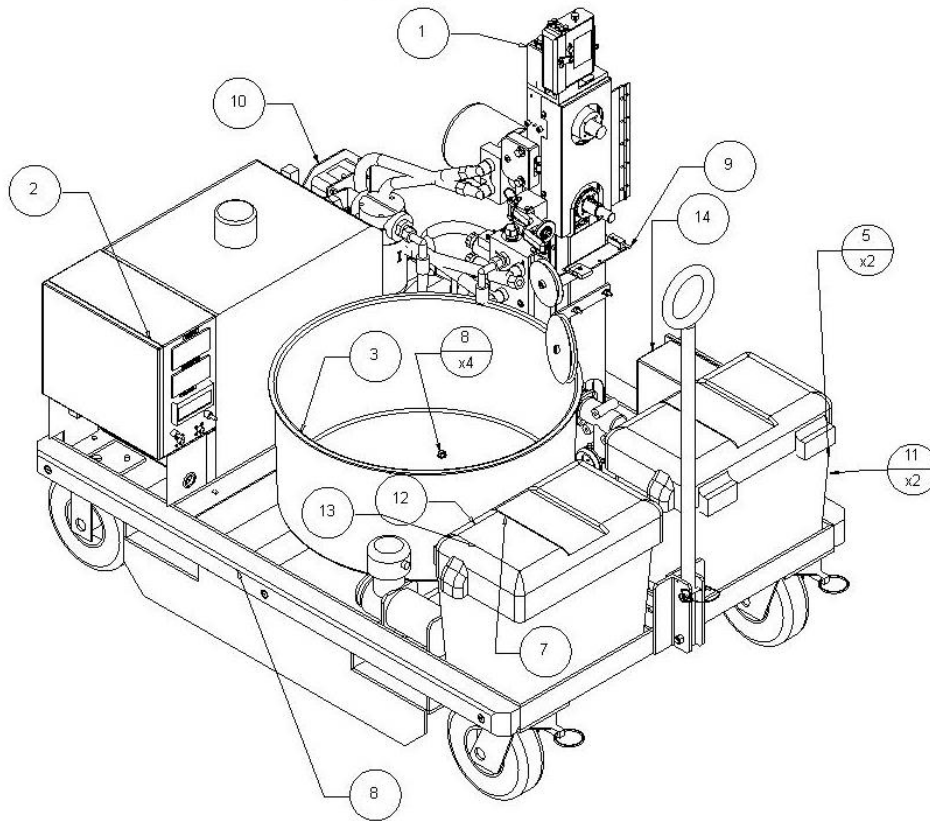

ZGS-10786-1

Item	Qty	Part Number	Part Name	Revision
1	1	ZGS-10374-1	Rocker Switch Assembly	
2	1	ZGS-10505-1	Control Station 3 Displays	
3	1	ZGS-10022-1	Tub , GSE	C
4	1	0312005.HXP	Fuse 5 amp	
5	2	ZGS-10058-1	8A31 MK Battery	
6	2	01500215Z	Fuse Holder in-line	
7	1	02980900Z	Mega Fuse Holder	
8	1	ZGS-10784-1	Hydraulic Subassembly	
9	1	ZGS-10771-1	LS Actuator Clevis Pin	
10	1	ZGS-10498-2	External Power Input Assembly v2	
11	2	ZGS-10078-1	Battery Box	
12	1	0298200	Mega Fuse	
13	1	0314015.HXP	Fuse 15 amp	
14	1	ZGS-10057-1	TPRO Charger	

Document Title		ZGS-10000-X-X Hydraulic Rescue Hoist Ground Support Equipment		
Document No.	Rev	Document Type	Release Date	
ZOM-10000-X	H	Operation & Maintenance Manual	Sept 20, 2022	

ZGS-10786-4

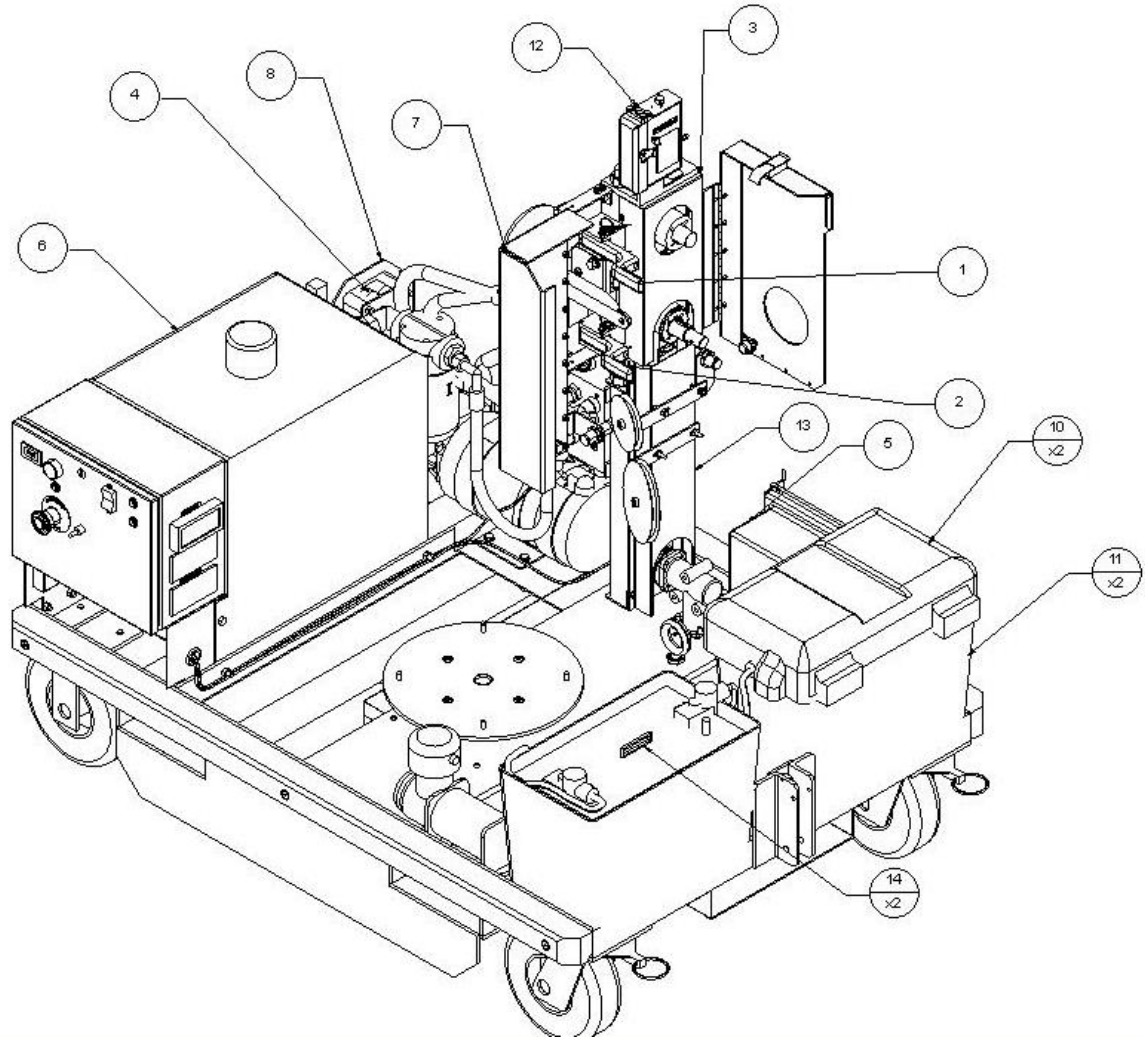

Item	Qty	Part Number	Part Name	Rev
1	1	ZGS-11221-1	Tensioner Pivot Arm, Upper	C
2	1	ZGS-11220-1	Tensioner Pivot Arm, Lower	B
3	1	ZGS-11064-3	Chain Guard Cover Assy CE	
4	1	ZGS-10915-1	Wire Harness - Power - Hydraulic CE	A
5	1	ZGS-10885-2	Battery Charger Dual Pro 220 v	
6	1	ZGS-10784-3	Hydraulic Subassembly CE	
7	1	ZGS-10743-1	Upright Cover Assembly	A
8	1	ZGS-10498-2	External Power Input Assembly v2	
9	2	ZGS-10105-1	Power Cord Z Bracket	A
10	2	ZGS-10078-2	Battery Box Top	
11	2	ZGS-10078-1	Battery Box	
12	1	ZGS-10048-1	LubriDryer Assembly	D
13	1	ZGS-10045-3	Belt Guard and Cover Assembly CE	
14	2	8A31DT	8A31DT Battery	

Document Title		ZGS-10000-X-X Hydraulic Rescue Hoist Ground Support Equipment		
Document No.	Rev	Document Type	Release Date	
ZOM-10000-X	H	Operation & Maintenance Manual	Sept 20, 2022	

ZGS-10784-1

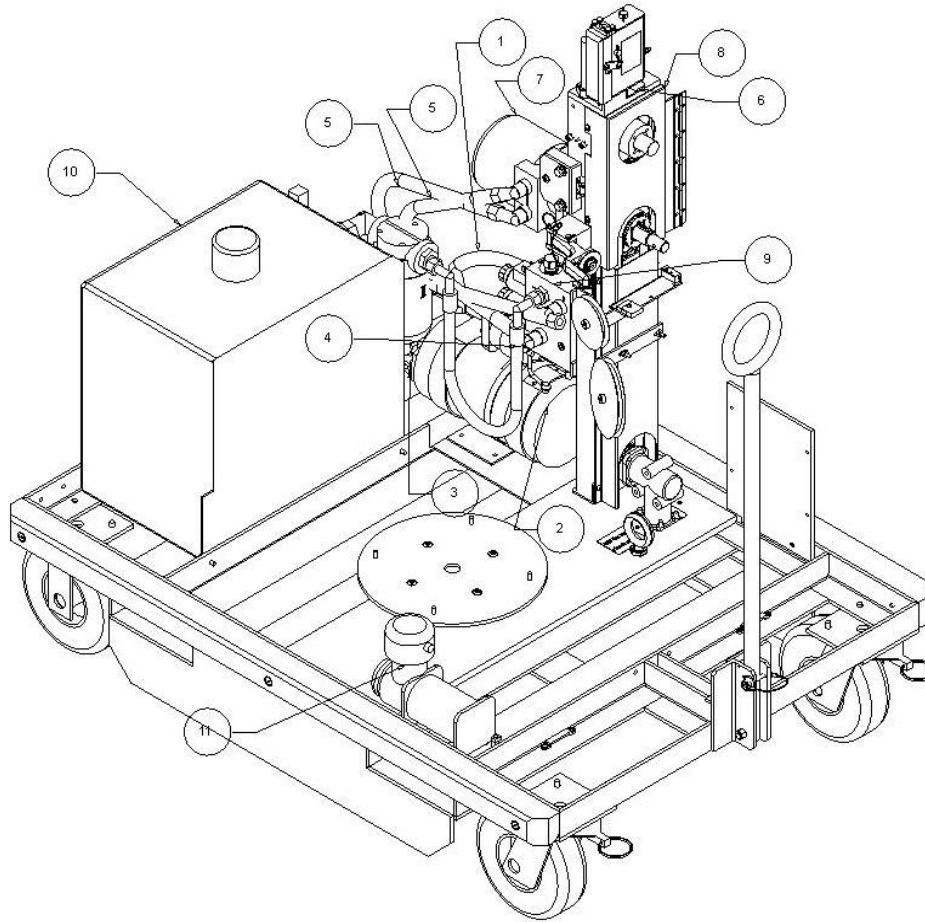

ZGS-10784-1

Item	QTY	Part Number	Part Name	Revision
1	1	ZGS-10077-1	Pressure Hose Assembly	C
2	1	ZGS-10017-1	Motor Pump Assembly	E
3	1	ZGS-10075-3	Inlet Hose Assy	A
4	1	ZGS-10076-1	Return Hose Assy A	D
5	2	ZGS-10072-3	Motor Hose 3	A
6	1	ZGS-10046-1	Latch Catch	F
7	1	ZGS-10102-1	Hydraulic Motor Assembly	
8	1	ZGS-10785-1	Frame and Upright Subassembly	
9	1	ZGS-10101-1	Hydraulic Manifold Assy	A
10	1	ZGS-10095-2	Hydraulic Tank Assembly v1	
11	1	ZGS-10052-1	32538 Viair Compressor	

Document Title		ZGS-10000-X-X Hydraulic Rescue Hoist Ground Support Equipment		
Document No.	Rev	Document Type	Release Date	
ZOM-10000-X	H	Operation & Maintenance Manual	Sept 20, 2022	

ZGS-10784-3

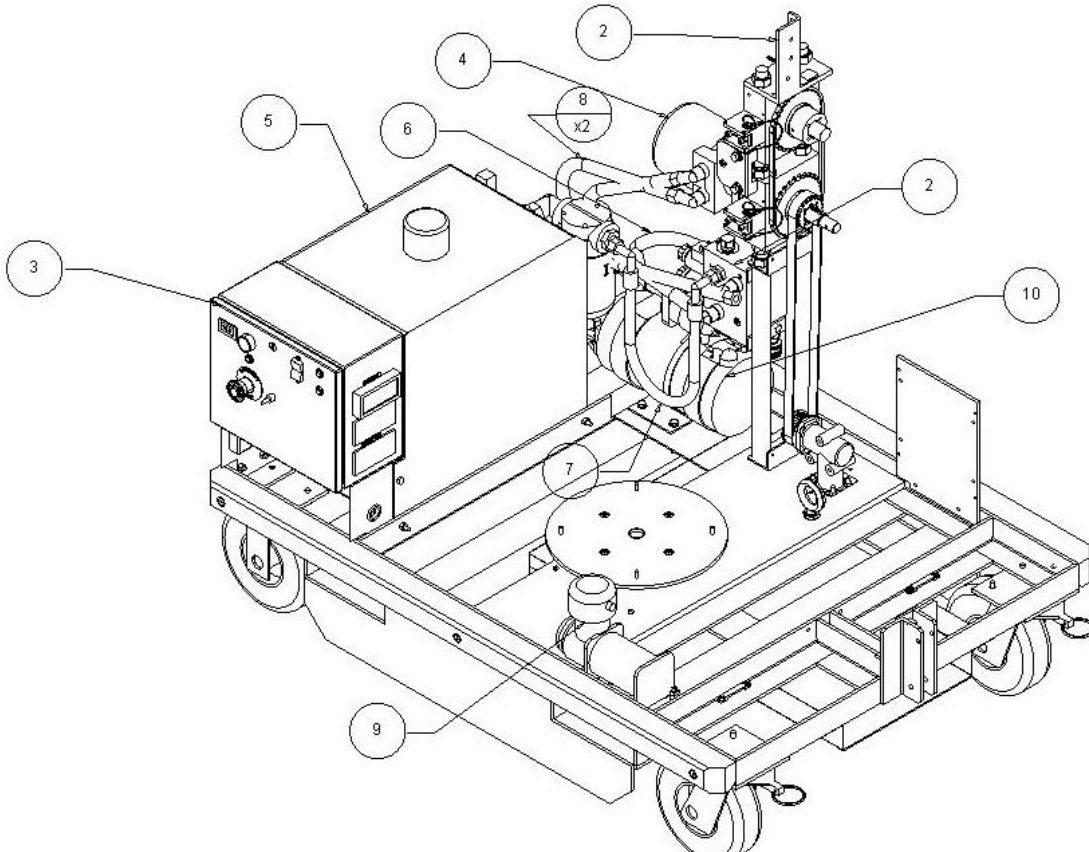

Item	Qty	Part Number	Part Name	Rev
1	1	ZGS-10870-1	Suction Line Assy	
2	1	ZGS-10785-3	Frame and Upright Subassembly CE	
3	1	ZGS-10505-1CE	Control Station 3 Displays CE	A
4	1	ZGS-10102-1	Hydraulic Motor Assembly	
5	1	ZGS-10095-2	Hydraulic Tank Assembly v1	
6	1	ZGS-10077-1	Pressure Hose Assembly	C
7	1	ZGS-10076-1	Return Hose Assy A	D
8	2	ZGS-10072-3	Motor Hose 3	A
9	1	ZGS-10052-1	32538 Viair Compressor	
10	1	ZGS-10017-1	Motor Pump Assembly	F

Document Title		ZGS-10000-X-X Hydraulic Rescue Hoist Ground Support Equipment		
Document No.	Rev	Document Type	Release Date	
ZOM-10000-X	H	Operation & Maintenance Manual	Sept 20, 2022	

ZGS-10785-1

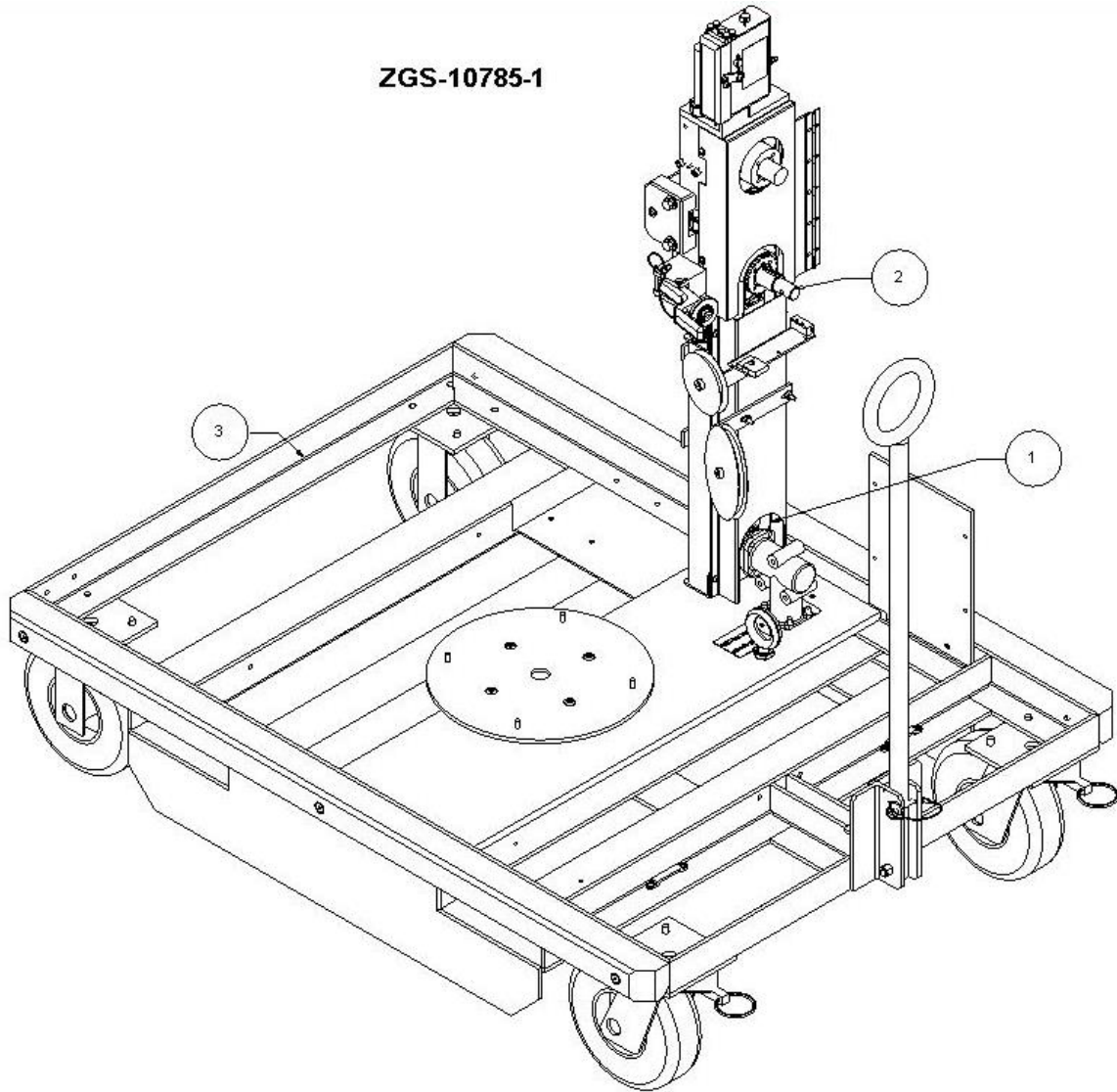

Item	Qty	Part Number	Part Name	Revision
1	1	ZGS-10040-1	Drive Belt, Vertical	
2	1	ZGS-14000-1	Upright assembly improved	A
3	1	ZGS-10359-1	Frame Subassembly	B

Document Title		ZGS-10000-X-X Hydraulic Rescue Hoist Ground Support Equipment		
Document No.	Rev	Document Type	Release Date	
ZOM-10000-X	H	Operation & Maintenance Manual	Sept 20, 2022	

ZGS-10785-3

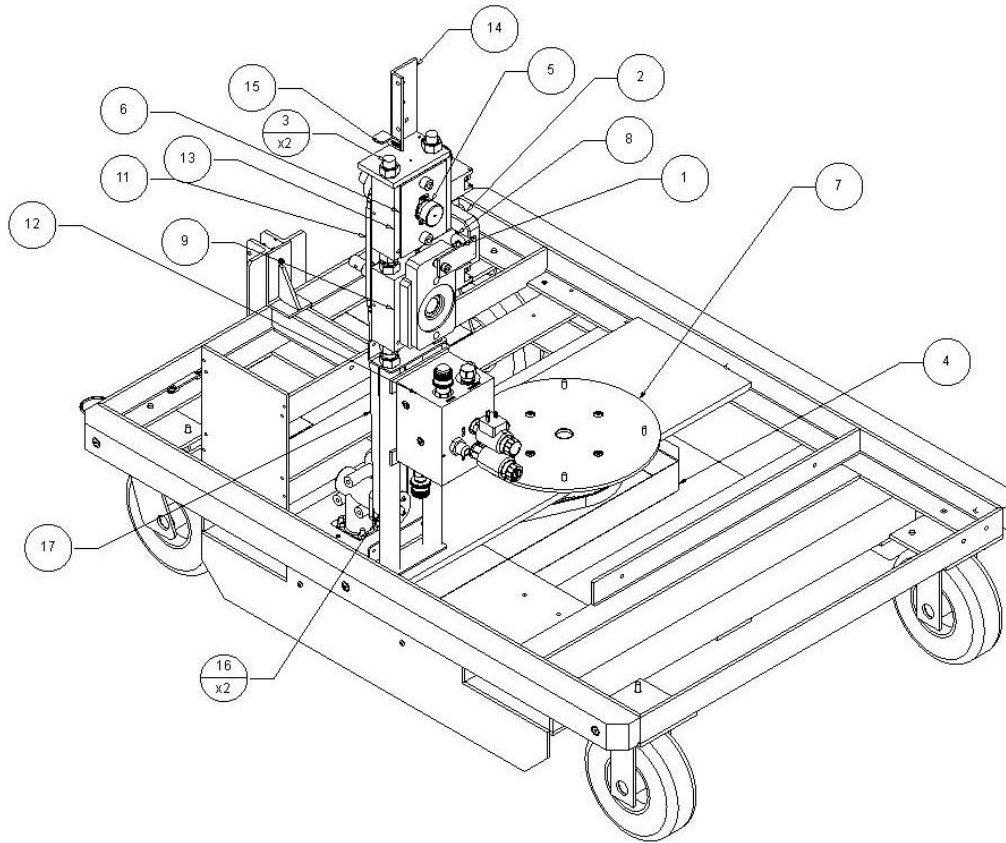

Item	Qty	Part Number	Part Name	Rev
1	1	ZGS-11113-1	Load reaction clevis	D
2	1	ZGS-11112-2	Load Brake Support ManGSE	D
3	2	ZGS-11011-1	Threaded Rod	
4	1	ZGS-10897-1	Rotatub Belt Cover	B
5	1	ZGS-10819-4	Encoder Assembly	
6	1	ZGS-10818-1	Red Lion Encoder Mounting Plate	
7	1	ZGS-10359-1	Frame Subassembly	C
8	1	ZGS-10316-2	Load Cell and extension Assembly	
9	1	ZGS-10297-1	Lower Head	D
10	2	ZGS-10114-2	Base, Tensioner Lite	C
11	1	ZGS-10107-1	Roller Chain	A
12	1	ZGS-10101-1	Hydraulic Manifold Assy	A
13	1	ZGS-10092-1	Upper Capstan Head Assy	G
14	1	ZGS-10085-1	Upright Bracket	M
15	1	ZGS-10046-1	Latch Catch	G
16	2	ZGS-10030-1	Upright Tube Upper	A
17	1	464576	Drive Belt, Vertical	

Document Title		ZGS-10000-X-X Hydraulic Rescue Hoist Ground Support Equipment		
Document No.	Rev	Document Type	Release Date	
ZOM-10000-X	H	Operation & Maintenance Manual	Sept 20, 2022	

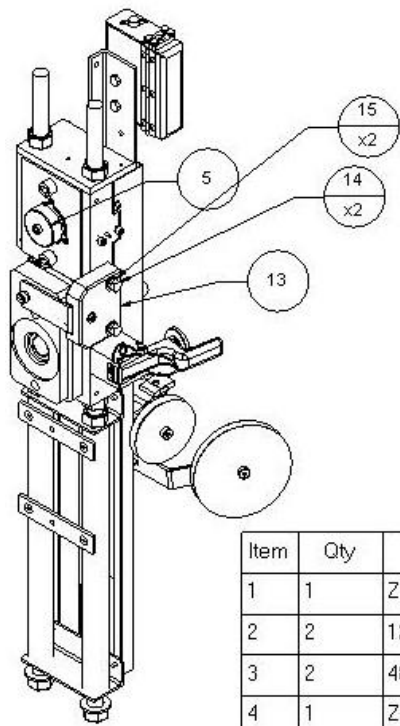

ZGS-14000-1

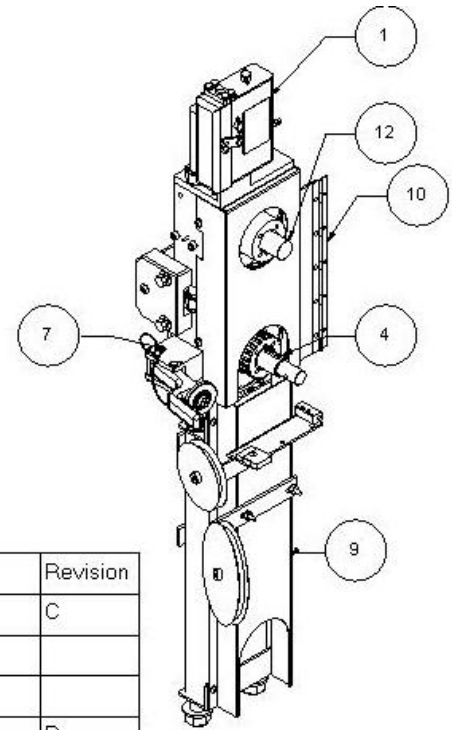

Item	Qty	Part Number	Part Name	Revision
1	1	ZGS-10048-1	LubriDryer Assembly	C
2	2	129	.25 x .75 cap screw	
3	2	4883	.25-20 x .75 long SHCS	
4	1	ZGS-10297-1	Lower Head	D
5	1	ZGS-10301-1	Encoder Plug Assembly	A
6	1	ZGS-10107-1	Roller Chain	A
7	1	ZGS-10128-1	Tensioner Assy Lower Open	B
8	8	1365	10-32 x .38 Pan Head Machine Screw	
9	1	ZGS-10045-1	Belt Guard and Cover Assembly	C
10	1	ZGS-11064-1	Chain Guard Cover Assy	A
11	4	4921	.5-13 SHCS 1in	
12	1	ZGS-10092-1	Upper Capstan Head Assy	G
13	1	ZGS-10832-1	Load Cell Assembly	
14	2	146	.312 x 1.5 Hex Bolt	
15	2	2948	.312 Flat Washer	

Document Title		ZGS-10000-X-X Hydraulic Rescue Hoist Ground Support Equipment		
Document No.	Rev	Document Type	Release Date	
ZOM-10000-X	H	Operation & Maintenance Manual	Sept 20, 2022	

ZGS-10359-1

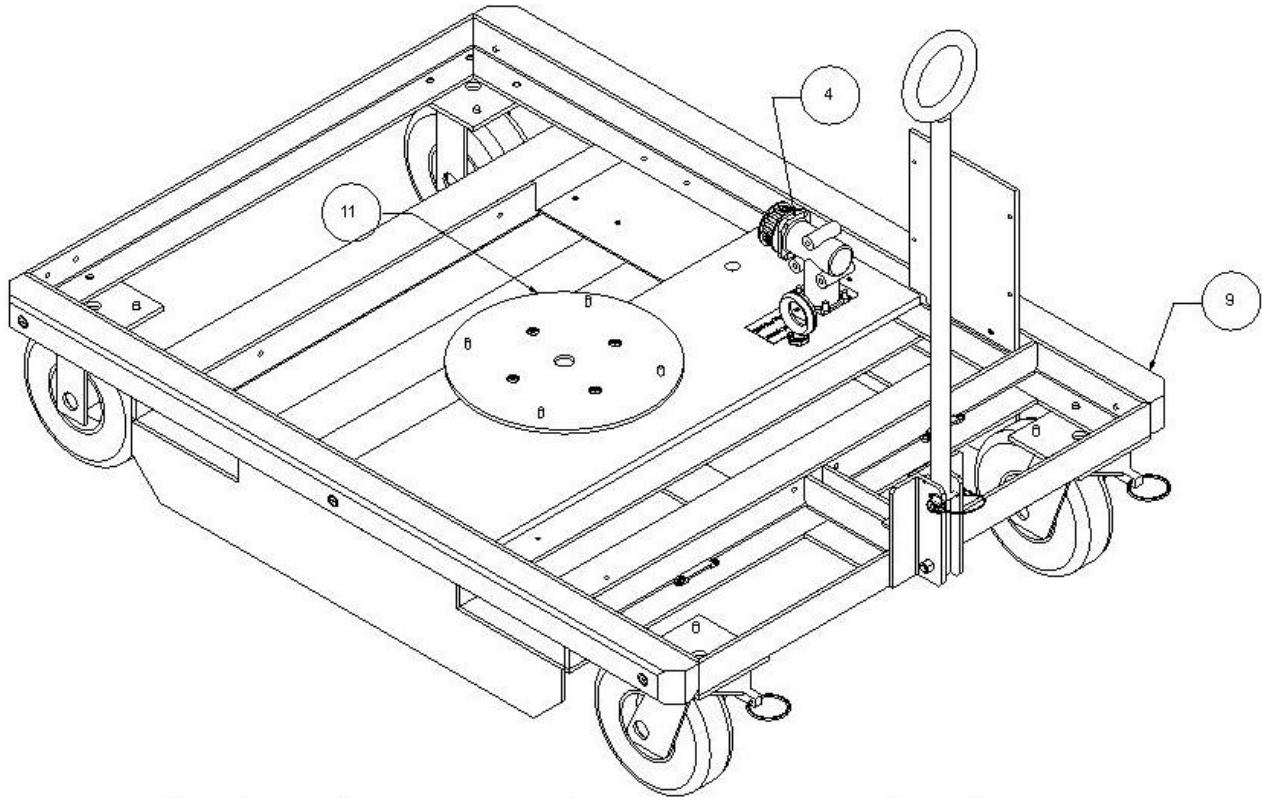

Item	Qty	Part Number	Part Name	Revision
1	1	SH-50SSMPSB100	Snap Ring	
2	1	ZGS-10122-1	Axel Key	
3	2	129	.25 x .75 cap screw	
4	1	ZGS-10012-1	Angle Drive Assy	B
5	1	ZGS-10132-1	Upper Base Bearing Assembly	B
6	1	ZGS-10477-1	Pulley, 6 inch Aluminum	A
7	1	ZGS-10132-2	Lower Base Bearing Assembly	B
8	1	A7X8 -C16250	Axel Sleeve .25 inch	
9	1	ZGS-10161-1	GSE Truck assembly	
10	1	ZGS-10025-1	Drive Belt, Drum	
11	1	ZGS-10248-1	Infinitely adjustable platen assy	C

Document Title		ZGS-10000-X-X Hydraulic Rescue Hoist Ground Support Equipment		
Document No.	Rev	Document Type	Release Date	
ZOM-10000-X	H	Operation & Maintenance Manual	Sept 20, 2022	

ZGS-10359-1

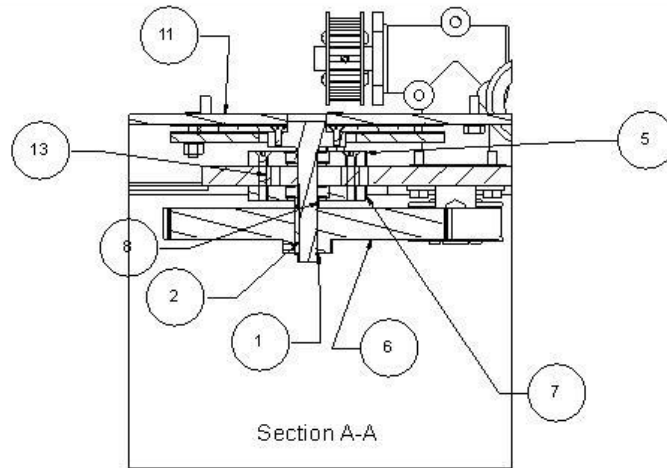
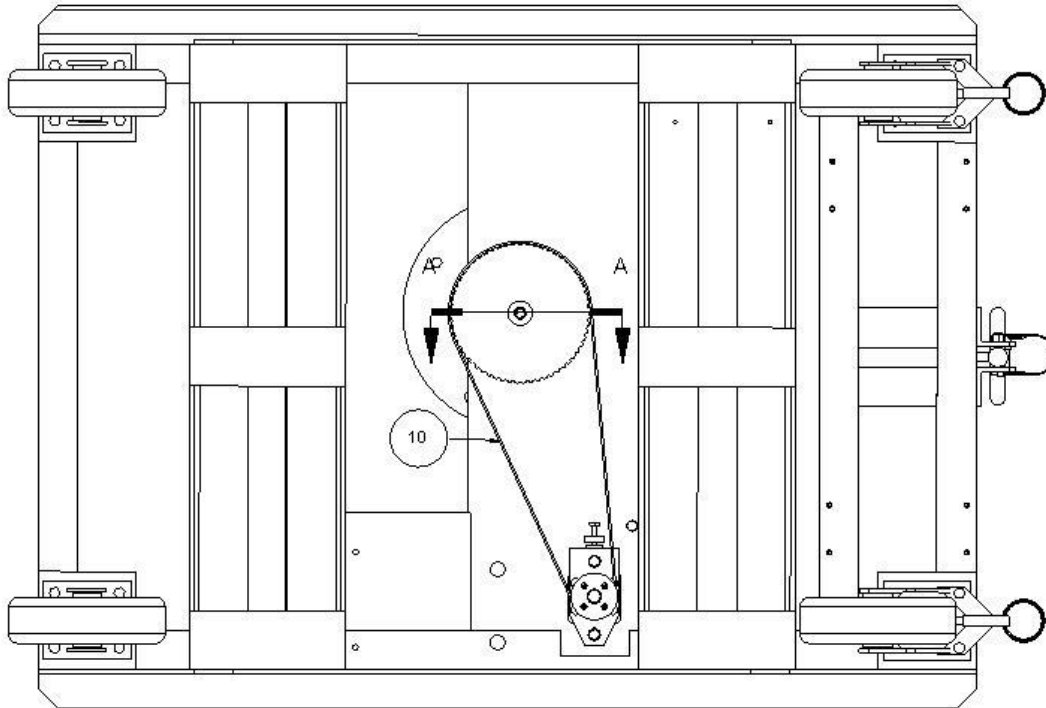

Document Title		ZGS-10000-X-X Hydraulic Rescue Hoist Ground Support Equipment		
Document No.	Rev	Document Type	Release Date	
ZOM-10000-X	H	Operation & Maintenance Manual	Sept 20, 2022	

ZGS-10129-1

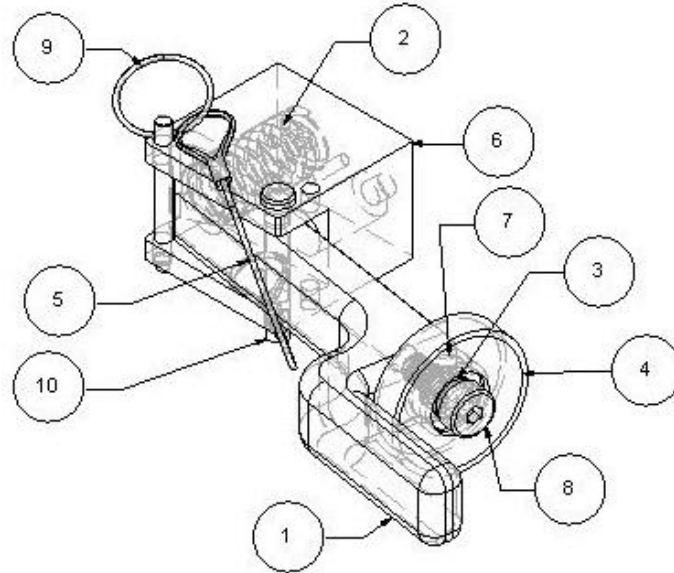

Item	Qty	Part Number	Part Name	REv
1	1	ZGS-11221-1	Tensioner Pivot Arm	
2	1	MCO08009SS	MCO08009SS Spring working height	A
3	1	A7x8-C12094	Tensioner Spacer	
4	1	ZGS-10294-1	Exit Roller Assy	B
5	1	ZGS-10330-1	Lanyard Assy	
6	1	ZGS-10114-2	Base, Tensioner Lite	C
7	1	91124A061	Shaft Spacer .01	
8	1	16497	Tensioner Roller Shaft	
9	1	FPSC3-15R	Tension Release Pin Long	
10	1	CLP-48S	Clevis Pin Tensioner	

Document Title		ZGS-10000-X-X Hydraulic Rescue Hoist Ground Support Equipment		
Document No.	Rev	Document Type	Release Date	
ZOM-10000-X	H	Operation & Maintenance Manual	Sept 20, 2022	

ZGS-10794-1

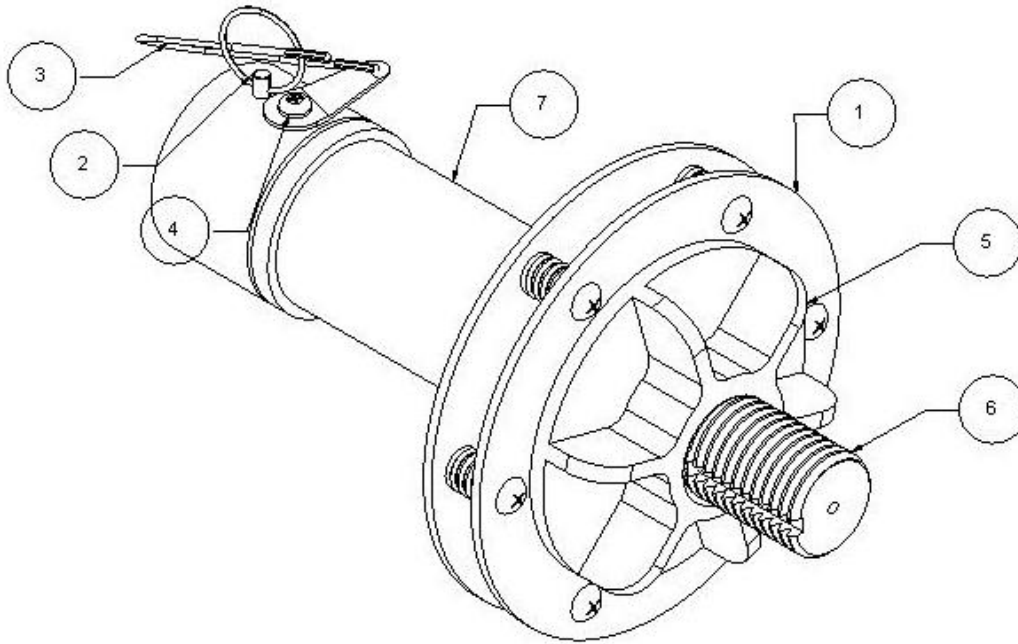

Item	Qty	Part Number	Part Name	Revision
1	1	ZGS-10787-1	Cable Reel Adapter Clutch Assembly	A
2	1	FPSC3-20R	Cable Reel Adapter Pin Long	
3	1	ZGS-11437-1	SB Lanyard Assy	
4	1	1366	10-32 x .5 Pan Head Machine Screw	
5	1	ZGS-10790-1	Cable Reel Adapter Torque Nut	A
6	1	ZGS-10456-2	Goodrich Shaft	A
7	1	ZGS-10455-1	Breeze Adapter	A

Document Title		ZGS-10000-X-X Hydraulic Rescue Hoist Ground Support Equipment		
Document No.	Rev	Document Type	Release Date	
ZOM-10000-X	H	Operation & Maintenance Manual	Sept 20, 2022	

ZGS-10628-1

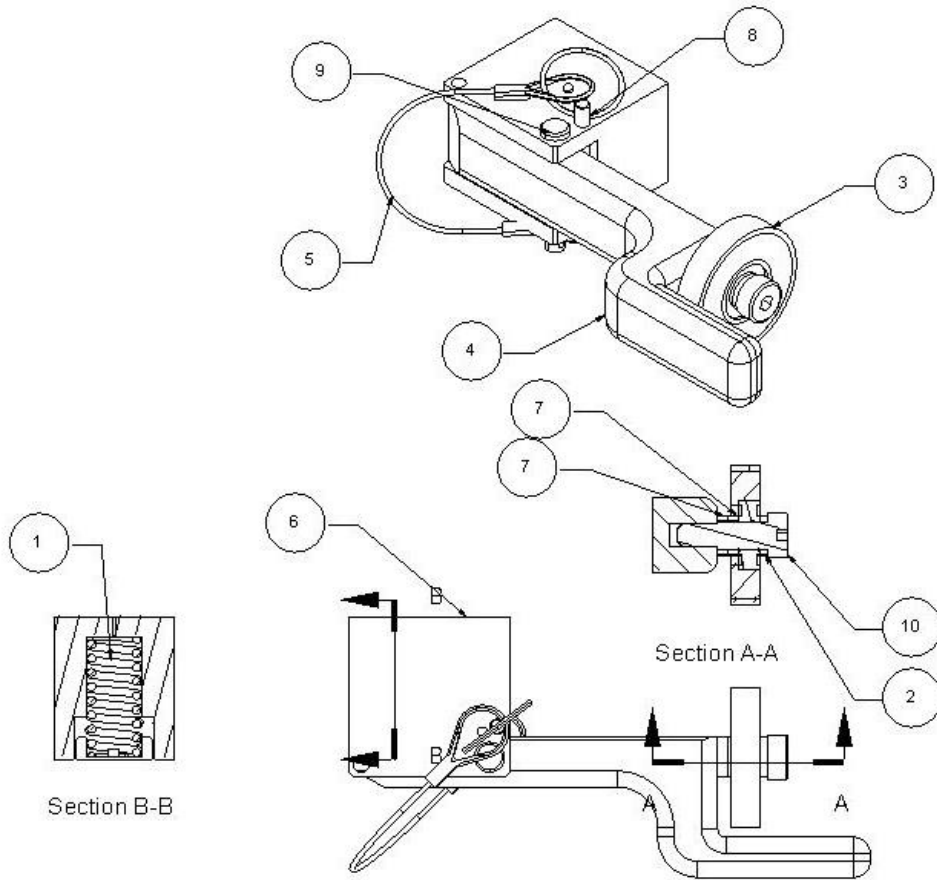

Item	Qty	Part Number	Part Name	Revision
1	1	MCO08009SS	MCO08009SS Spring working height	A
2	1	A7x 8-C12094	Tensioner Spacer	
3	1	ZGS-10294-1	Exit Roller Assy	B
4	1	ZGS-11221-1	Tensioner Pivot Arm, Upper	A
5	1	ZGS-10330-1	Lanyard Assy	
6	1	ZGS-10114-2	Base, Tensioner Lite	C
7	2	A7X8-C12125	3-8 shaft spacer .12 long	
8	1	FPSC3-15R	Tension Release Pin Long	
9	1	CLP-48S	Clevis Pin Tensioner	
10	1	16499	.375 shoulder bolt .63 long	

Document Title		ZGS-10000-X-X Hydraulic Rescue Hoist Ground Support Equipment		
Document No.	Rev	Document Type	Release Date	
ZOM-10000-X	H	Operation & Maintenance Manual	Sept 20, 2022	

ZGS-10505-1

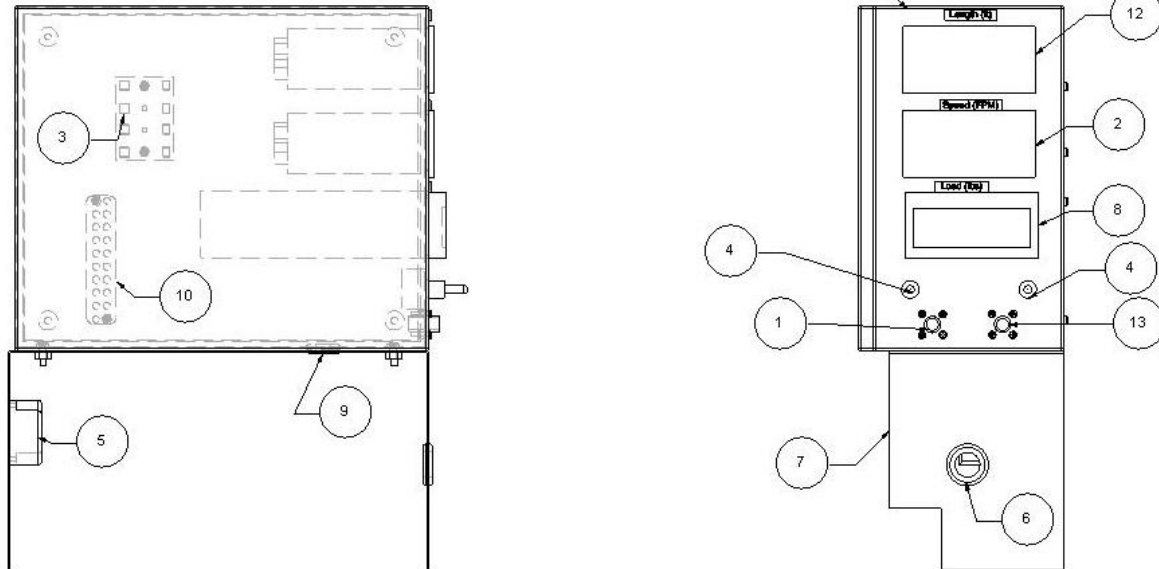

Item	Qty	Part Number	Part Name	Rev
1	1	MS3112E8-4P	Box Receptacle, Load	
2	1	ZGS-10192-2	Cable Speed Digital Display	
3	1	ZGS-10168-1	Fuse Block	
4	2	S301T-RO	Power Switch	
5	1	ZGS-10191-1	Piezo Siren	C
6	1	GR-5128	Grommet .75 ID	
7	1	ZGS-10158-1	Box Support	
8	1	ZGS-12109-3	Load Cell Display Meter 12 VDC	
9	1	GR-5158	Grommet	
10	1	ZGS-10163-1	Terminal Board	
11	1	ZGS-10292-2	Control Box 3 Displays	
12	1	ZGS-10192-1	Cable Length Digital Display	
13	1	MS3112E8-4S	Box Receptacle, length	

Document Title		ZGS-10000-X-X Hydraulic Rescue Hoist Ground Support Equipment		
Document No.	Rev	Document Type	Release Date	
ZOM-10000-X	H	Operation & Maintenance Manual	Sept 20, 2022	

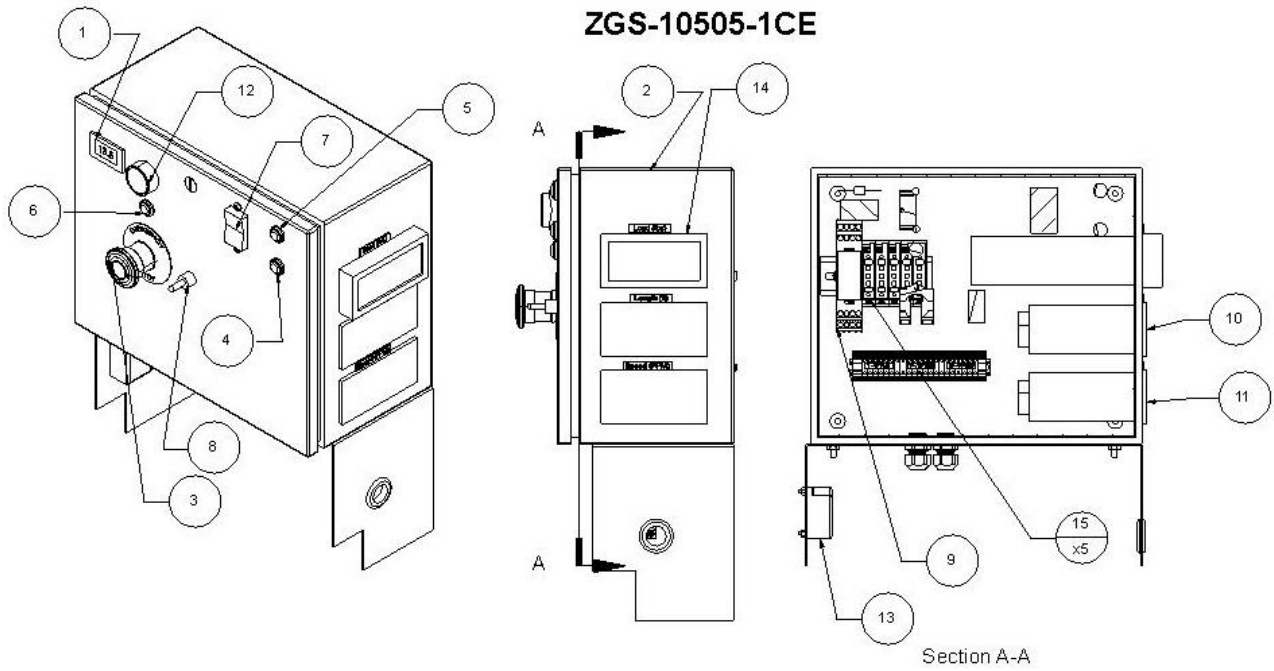

Item	Qty	Part Number	Part Name	Rev	Cost	Vendor	LT wks
1	1	ZGS-10780-2	Voltmeter		\$10.96	Amazon	
2	1	ZGS-10292-2-CE	Control Box 3 Displays CE	B	\$270	Custom	10
3	1	XB4BT845	Emergency Stop Switch		\$85.74		
4	1	WL-1090QC5-28v	Indicator Light Green 24 vdc		\$3.02	Allied	
5	1	WL-1090C3-28V	Indicator Light amber 24 vdc		\$2.4	Allied	4
6	1	WL-1090C1-28V	Indicator Light Red 24 vdc		\$2.81	Allied	4
7	1	SW3823	SW3823 Rocker Switch		\$26.47	Allied	4
8	1	S301T	Power Switch		\$8.98	Allied	
9	1	LG5925-48-61-24	Safety Gate relay 24 volts		\$124.00	Auto Dir	4
10	1	L81200QD	Cable Length Digital Display		\$405	PC&S	5
11	1	L81000QD	Cable Speed Digital Display		\$347	PC&S	5
12	1	GCX1100	Pushbutton Momentary		\$7.25		
13	1	ES-10	Piezo Siren	C	\$4.0	All Electronics	4
14	1	DP25B-S-DC 10/32	Load Cell Display Meter 12 VDC		\$435.91	Omega	6
15	5	1014000000	Fused Terminal Block		\$6.52	Newark	

Document Title		ZGS-10000-X-X Hydraulic Rescue Hoist Ground Support Equipment		
Document No.	Rev	Document Type	Release Date	
ZOM-10000-X	H	Operation & Maintenance Manual	Sept 20, 2022	

ZGS-10498-2

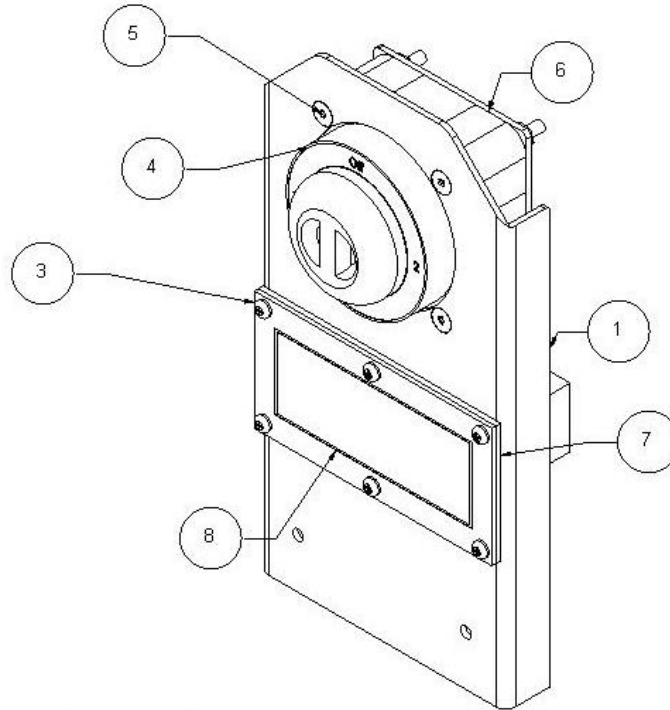

Item	Qty	Part Number	Part Name	Rev
1	1	ZGS-12670-1	28 Volt Input Mounting Plate	C
2	4	2554	.25 Lock nut	
3	6	1366	10-32 x .5 Pan Head Machine Screw	
4	1	ZGS-10616-1	Battery Switch	
5	4	1284	.25-20 Flat Head 2.5 long	
6	1	ZGS-10613-1	Battery Switch Cover	
7	1	ZGS-12497-1	28 volt Receptacle Gasket	
8	1	4650B	28 volt Receptacle	

Document Title		ZGS-10000-X-X Hydraulic Rescue Hoist Ground Support Equipment		
Document No.	Rev	Document Type	Release Date	
ZOM-10000-X	H	Operation & Maintenance Manual	Sept 20, 2022	

ZGS-10017-1

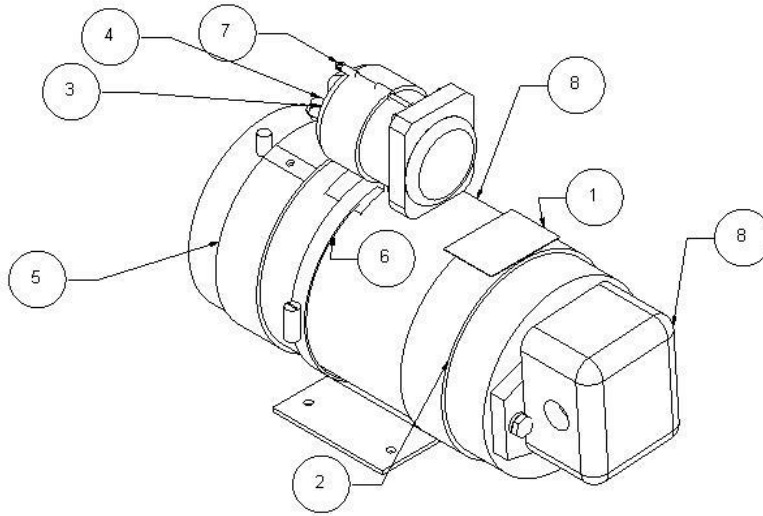

Item	Qty	Part Number	Part Name	Rev
1	1	MS01:J6111-FF	Label, Burn Hazard	
2	1	ZGS-10087-2	Motor Vent Cover B	
3	1	ZGS-10065-1	Motor Starter Solenoid	B
4	1	ZGS-10312-1	Relay To Motor Positive Wire Assembly	
5	1	ZGS-10087-1	Motor Vent Cover A	
6	1	ZGS-10086-1	Motor Relay Band Clamp	
7	1	ZGS-10414-1	Noise Suppressor Assembly	
8	1	ZGS-10071-1	Motor Pump Kit	C

Document Title		ZGS-10000-X-X Hydraulic Rescue Hoist Ground Support Equipment		
Document No.	Rev	Document Type	Release Date	
ZOM-10000-X	H	Operation & Maintenance Manual	Sept 20, 2022	

ZGS-10101-1

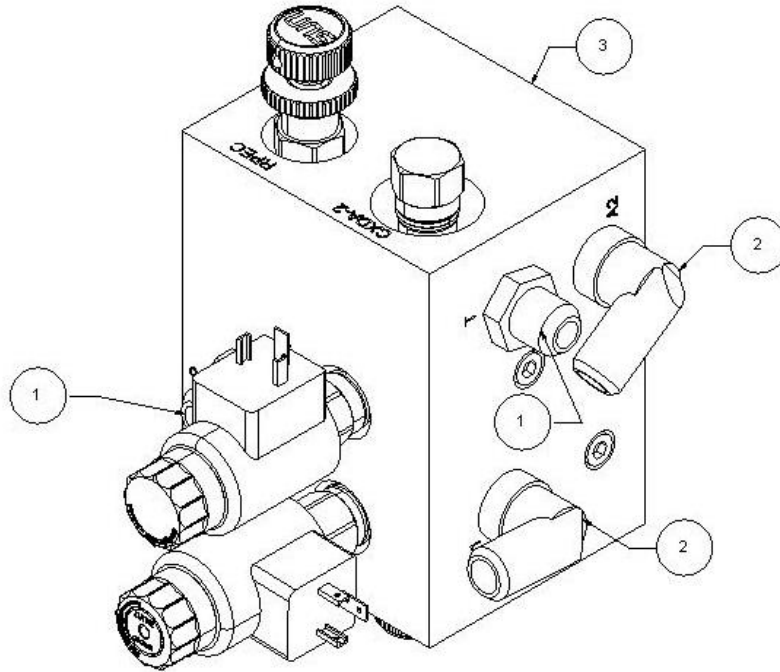

Item	Qty	Part Number	Part Name	Revision
1	2	8-10 F50X	8-10 F50X Straight thread Connector	
2	2	8-10 C50X	8-10 C50X Straight thread elbow	
3	1	ZGS-10068-1	Manifold Assy	

Document Title		ZGS-10000-X-X Hydraulic Rescue Hoist Ground Support Equipment		
Document No.	Rev	Document Type	Release Date	
ZOM-10000-X	H	Operation & Maintenance Manual	Sept 20, 2022	

ZGS-10095-2

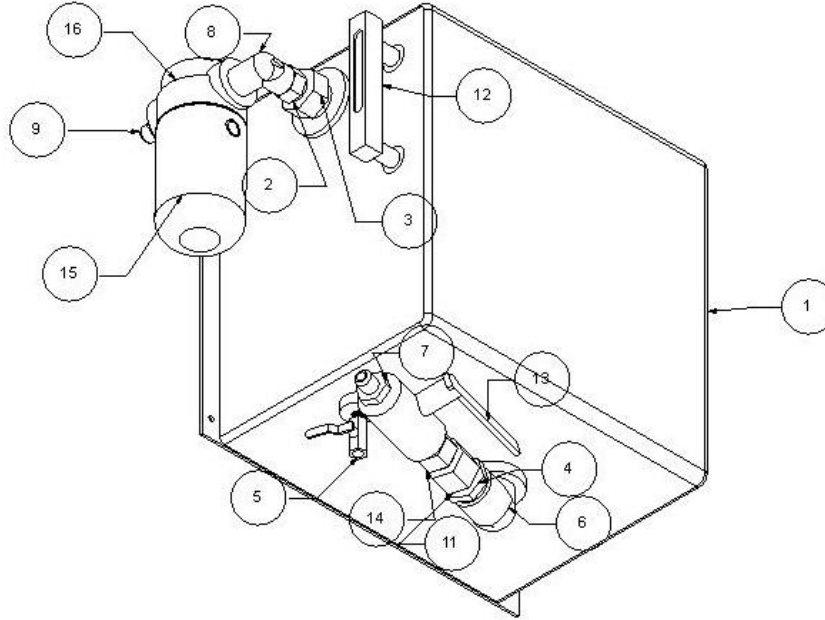

Item	Qty	Part Number	Part Name	Rev
1	1	ZGS-10070-1	Hydro Slave Tank	
2	1	12-3/4 F50F	12- .75 F50F Adapter	
3	1	1 1/4 x 3/4 PTR	1.25 x.75 PTR	
4	1	1.25 x 1 PTR	1.25 x 1 PTR	
5	1	ZGS-10252-1	.25 Ball Valve	
6	1	1 1/4CD	1.25 NPT Street Elbow	
7	1	12-16 F50X	12-16 F50X Straight thread Connector	
8	1	12 A0EG5	SAE 12 Elbow	
9	1	8-12 F50X	8-12 F50X Straight thread Connector	
10	1	02204352	.25 close nipple	
11	1	1-16 FHG5	1-16 FHG5	
12	1	G617-05-A-1-4	Sight Gage	
13	1	77-905-01	Ball Valve SAE Ports	
14	1	16 F50HAO	16 F50HAO	
15	1	ZGS-10069-2	Hydraulic Filter Element	
16	1	ZGS-10069-3	Hydraulic Filter Head	

Document Title		ZGS-10000-X-X Hydraulic Rescue Hoist Ground Support Equipment		
Document No.	Rev	Document Type	Release Date	
ZOM-10000-X	H	Operation & Maintenance Manual	Sept 20, 2022	

ZGS-10048-1

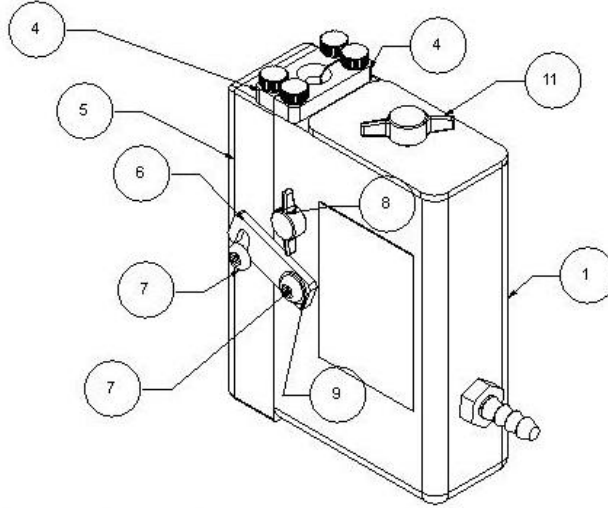

Item	Qty	Part Number	Part Name	Revision	Comment
1	1	ZGS-10055-1	Oiler Tank Air Housing	J	
2	1	ZGS-10050-1	Capstan Hinge		not shown
3	6	1345	8 32 x .38		not shown
4	2	ZGS-10739-1	Lubridyer Bushing Assembly		
5	1	ZGS-10049-1	Oiler Dryer Front	F	
6	1	ZGS-10051-1	Oiler Latch	A	
7	2	1366	10 32 x 5		
8	1	ZGS-10361-1	#10 Thumbscrew		
9	1	91545A240	#10 Nylatron Washer		
10	2	ZGS-10104-1	Lubridyer Pad		not shown
11	1	ZGS-10831-1	Lubridyer Reservoir Cover		

Document Title		ZGS-10000-X-X Hydraulic Rescue Hoist Ground Support Equipment		
Document No.	Rev	Document Type	Release Date	
ZOM-10000-X	H	Operation & Maintenance Manual	Sept 20, 2022	

ZGS-10297-1

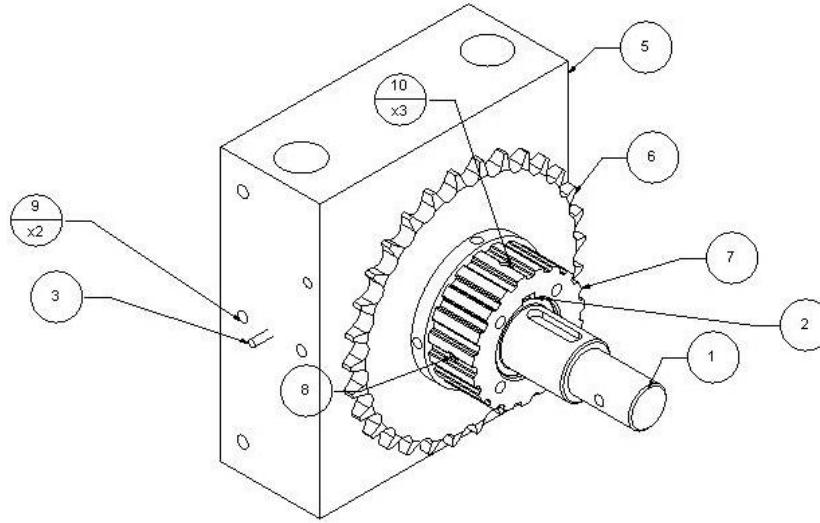

Item	QTY	Part Number	Part Name	Rev	Comment
1	1	ZGS-10035-2	Lower Capstan Shaft Load Indicating		
2	1	ZGS-10123-1	Capstan Pulley Key		
3	1	06022065	.125 Dowel Pin .63 long		
4	2	SS62082RS	Bearing, Head		not shown
5	1	ZGS-10033-1	Head Stock Universal	H	
6	1	ZGS-10422-1	Capstan Drive Sprocket Weldment	B	
7	1	ZGS-10036-1	Capstan Pulley	D	
8	1	09578949	.188 Roll Pin 2 inch long		
9	2	7029	.25-20 x .25 Set Screw		
10	3	7020	10-32 x .25 Setscrew		

Document Title		ZGS-10000-X-X Hydraulic Rescue Hoist Ground Support Equipment		
Document No.	Rev	Document Type	Release Date	
ZOM-10000-X	H	Operation & Maintenance Manual	Sept 20, 2022	

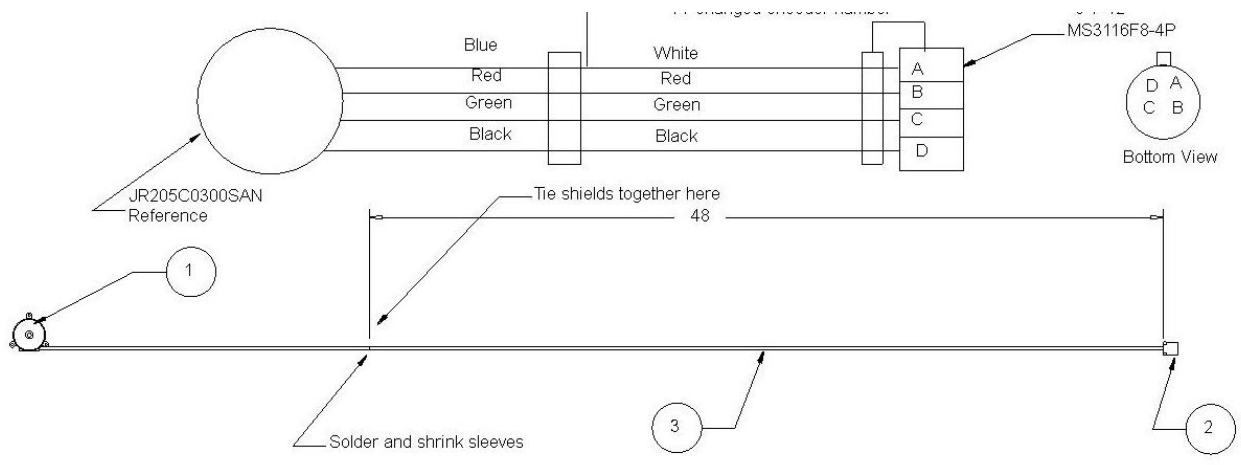

Item Number	Quantity	Part Number	Part Name	Revision	Comment
1	1	ZGS-10201-1	Encoder	A	strip 1 inch
2	1	MS3116F8-4P	Plug Connector, Encoder		
3	1	4 conductor shielded	Encoder Wire 2		

Document Title		ZGS-10000-X-X Hydraulic Rescue Hoist Ground Support Equipment		
Document No.	Rev	Document Type	Release Date	
ZOM-10000-X	H	Operation & Maintenance Manual	Sept 20, 2022	

ZGS-10128-1

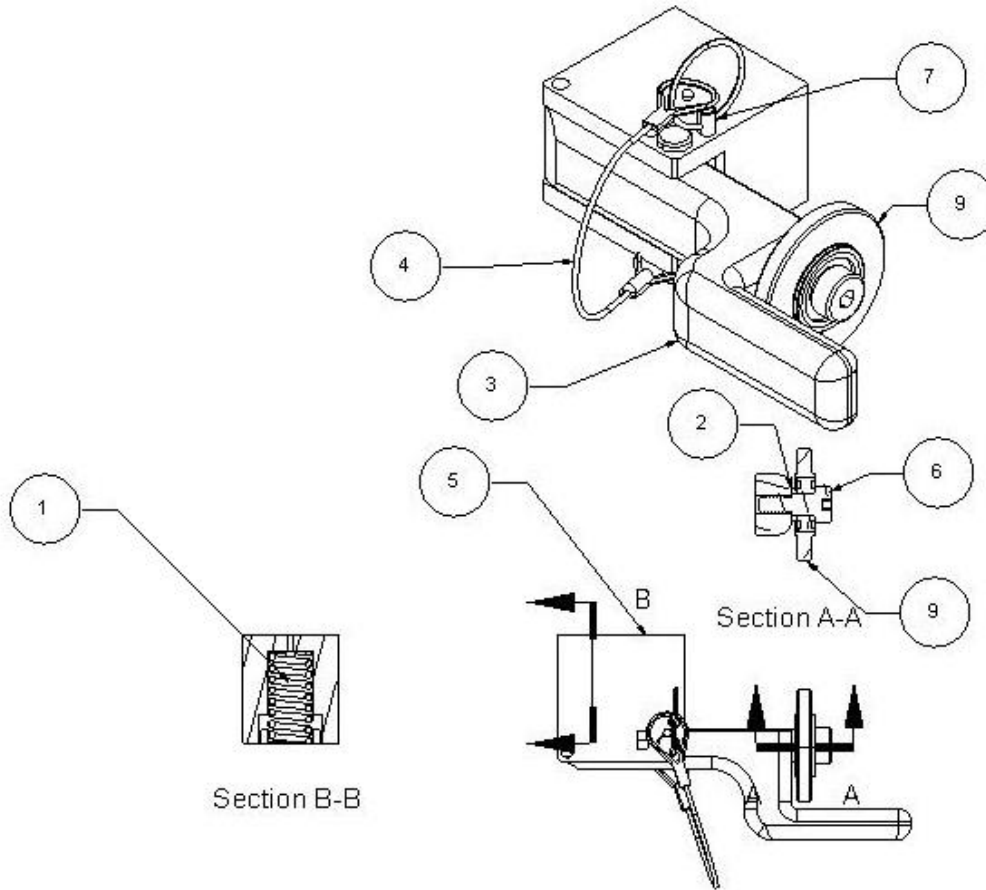

Item	Qty	Part Number	Part Name	Rev
1	1	MCO08009SS	MCO08009SS Spring working height	A
2	1	A7x 8-C12094	Tensioner Spacer	
3	1	ZGS-11220-1	Pivot Arm, Lower	
4	1	ZGS-10330-1	Lanyard Assy	
5	1	ZGS-10114-2	Base, Tensioner Lite	C
6	1	16497	Tensioner Roller Shaft	
7	1	FPSC3-15R	Tension Release Pin Long	
8	1	CLP-48S	Clevis Pin Tensioner	
9	1	ZGS-10127-1	Pressure Roller Assy	B

Document Title		ZGS-10000-X-X Hydraulic Rescue Hoist Ground Support Equipment		
Document No.	Rev	Document Type	Release Date	
ZOM-10000-X	H	Operation & Maintenance Manual	Sept 20, 2022	

ZGS-10045-1

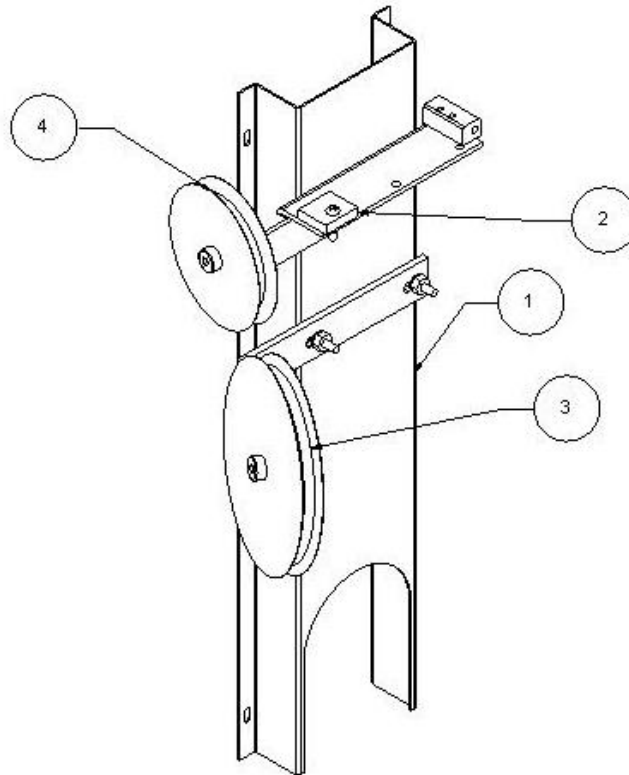

Item	Qty	Part Number	Part Name	Rev
1	1	ZGS-10079-1	Vertical Belt Guard Cover	F
2	1	ZGS-10501-1	Capstan Cover Stop	
3	1	ZGS-10363-1	Tension Wheel Assembly Large	
4	1	ZGS-10362-1	Tension Wheel Assembly Small	

Document Title		ZGS-10000-X-X Hydraulic Rescue Hoist Ground Support Equipment		
Document No.	Rev	Document Type	Release Date	
ZOM-10000-X	H	Operation & Maintenance Manual	Sept 20, 2022	

ZGS-10092-1

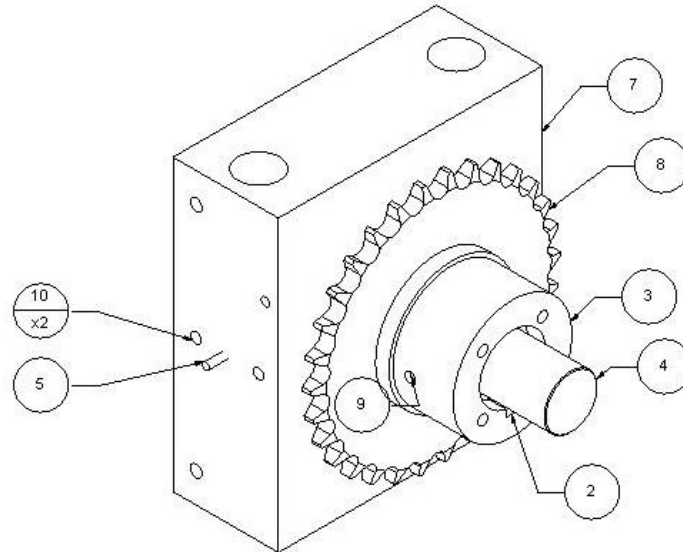

Item	Qty	Part Number	Part Name	Rev	Comment
1	1	98381A550	.25 Pin 2.0 long		not shown
2	1	ZGS-10123-1	Capstan Pulley Key		
3	1	ZGS-10475-1	Capstan Upper Attachment	A	
4	1	ZGS-10038-1	Upper Capstan Drive Shaft	F	
5	1	06022065	.125 Dowel Pin .63 long		
6	2	SS62082RS	Bearing, Head		
7	1	ZGS-10033-1	Head Stock Universal	H	
8	1	ZGS-10422-1	Capstan Drive Sprocket Weldment	B	
9	1	09578949	.188 Roll Pin 2 inch long		
10	2	7029	.25-20 x .25 Set Screw		not shown
11	3	7020	10-32 x .25 Setscrew		

Document Title		ZGS-10000-X-X Hydraulic Rescue Hoist Ground Support Equipment		
Document No.	Rev	Document Type	Release Date	
ZOM-10000-X	H	Operation & Maintenance Manual	Sept 20, 2022	

ZGS-10832-1

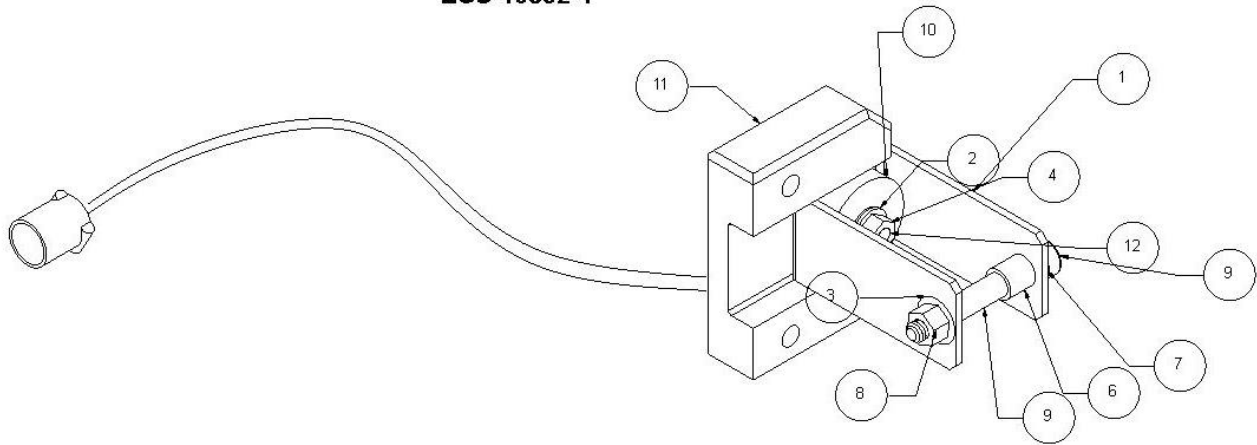

Item Number	Quantity	Part Number	Part Name	Revision	Comment
1	1	ZGS-11113-1	Load reaction clevis	D	
2	1	2947	.25 Flat Washer		
3	1	2948	.312 Flat Washer		PFHZZ
4	1	2554	.25 Lock nut		PFHZZ
5	1	2932	Fender Washer		
6	1	A7 x8 C12500	3-8 shaft spacer .5 long		
7	2	A7X8-C12125	3-8 shaft spacer .12 long		
8	1	2555	.312 locknut		PFHZZ
9	1	14080	.375 stripper bolt 2 long		
10	1	ZGS-10316-1	Load Cell Plug Assembly		
11	1	ZGS-11112-1	Load Brake Support	G	
12	1	9802	1-4 x 28 x 1.5 machine screw		

Document Title		ZGS-10000-X-X Hydraulic Rescue Hoist Ground Support Equipment		
Document No.	Rev	Document Type	Release Date	
ZOM-10000-X	H	Operation & Maintenance Manual	Sept 20, 2022	

ZGS-10012-1

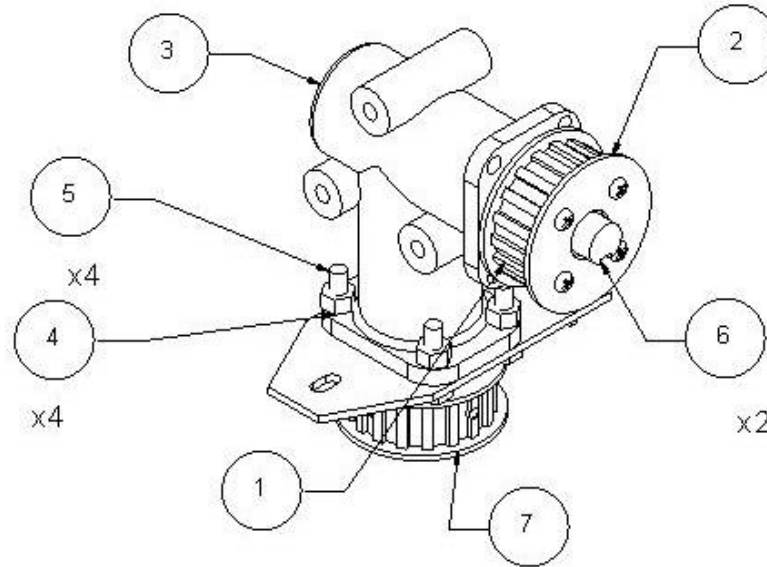

Item	Qty	Part Number	Part Name	Rev
1	1	09578907	.188 Roll Pin 1.5 long	
2	1	ZGS-10479-2	2 inch Pulley Assembly upper	A
3	1	ZGS-10013-1	AnglGear	
4	4	2554	.25 Lock nut	
5	4	130	.25 x 1 cap screw	
6	2	3/16 x 1 Key	.188 Key x 1 inch long	
7	1	ZGS-10479-1	2 inch Pulley Assembly	

ZGS-10132-1

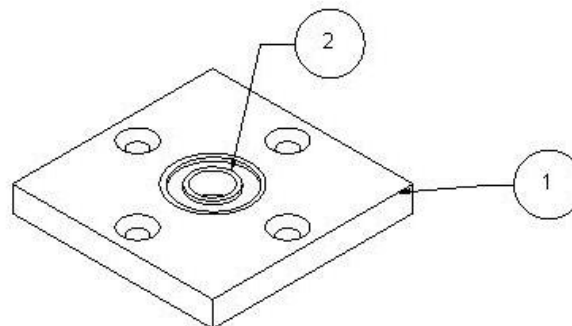

Item	Qty	Part Number	Part Name	Rev
1	1	ZGS-10094-1	Upper base bearing support alt	
2	1	SSR82RS	Bearing, Base	A

Document Title		ZGS-10000-X-X Hydraulic Rescue Hoist Ground Support Equipment		
Document No.	Rev	Document Type	Release Date	
ZOM-10000-X	H	Operation & Maintenance Manual	Sept 20, 2022	

ZGS-10132-2

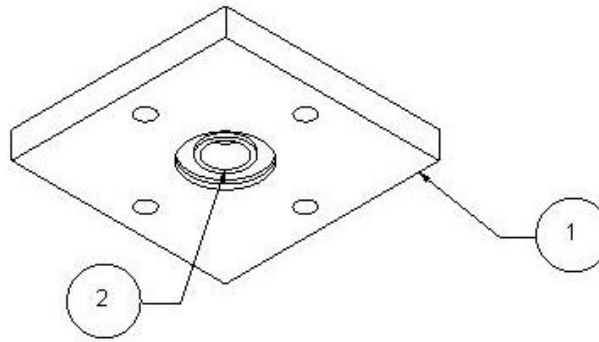

Item	Qty	Part Number	Part Name	Rev
1	1	ZGS-10094-2	Lower base bearing support alt	
2	1	SSR82RS	Bearing, Base	A

Document Title		ZGS-10000-X-X Hydraulic Rescue Hoist Ground Support Equipment		
Document No.	Rev	Document Type	Release Date	
ZOM-10000-X	H	Operation & Maintenance Manual	Sept 20, 2022	

ZGS-10248-1

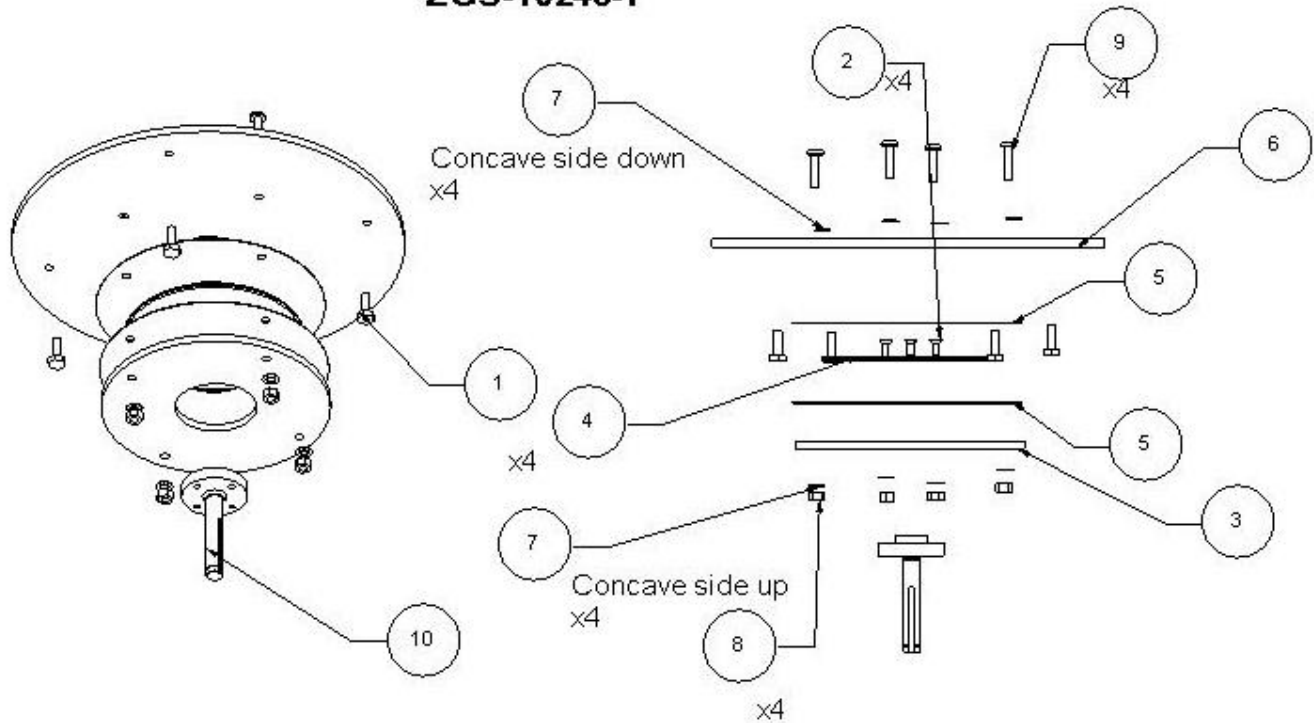

Item	Qty	Part Number	Part Name	Rev
1	4	129	.25 x .75 cap screw	
2	4	4475	10-32 Flat Head .5 long	
3	1	ZGS-10176-2	Infinity adjustable Lower plate	A
4	1	ZGS-10175-2	Infinity Adjustable Platen Plate	C
5	2	ZGS-10737-1	Infinity adjustable Slip Pad	
6	1	ZGS-10180-2	Infinity Adjustable Platen Top Plate	B
7	8	87779237	Belleville Washer	
8	4	4108	.25-28 Lock nut	
9	4	5725	1-4 x 28 x 1 machine screw	
10	1	ZGS-10020-1	Axel	F

Torque items 9 and 8 to 14-15 in-oz. 4 places
 Check without holding the nut
 Use Loctite 222 on item 2

Document Title		ZGS-10000-X-X Hydraulic Rescue Hoist Ground Support Equipment		
Document No.	Rev	Document Type	Release Date	
ZOM-10000-X	H	Operation & Maintenance Manual	Sept 20, 2022	

ZGS-10971-1

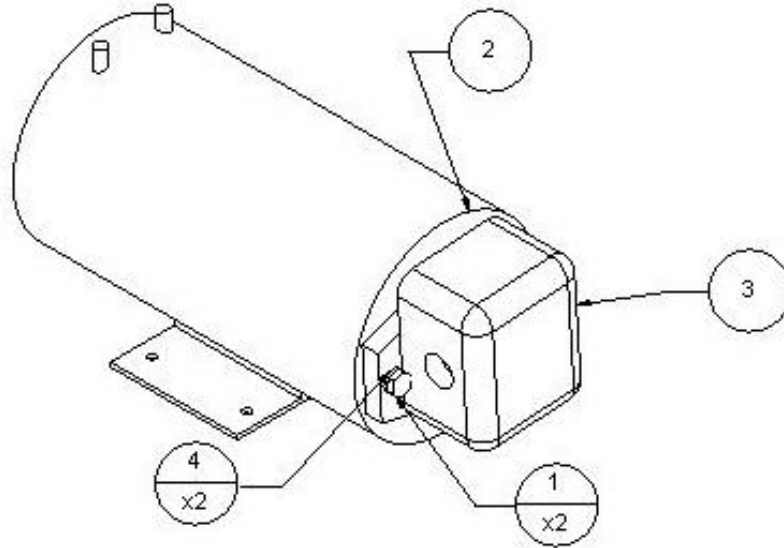

Item	Qty	Part Number	Part Name	Rev
1	2	744	3-8 -24 x 1 inch long	
2	1	ZGS-10499-1	24 VDC Motor	
3	1	ZGS-10424-1	Hydraulic Pump	D
4	2	3039	3-8 Lock Washer	

Document Title		ZGS-10000-X-X Hydraulic Rescue Hoist Ground Support Equipment		
Document No.	Rev	Document Type	Release Date	
ZOM-10000-X	H	Operation & Maintenance Manual	Sept 20, 2022	

ZGS-10068-1

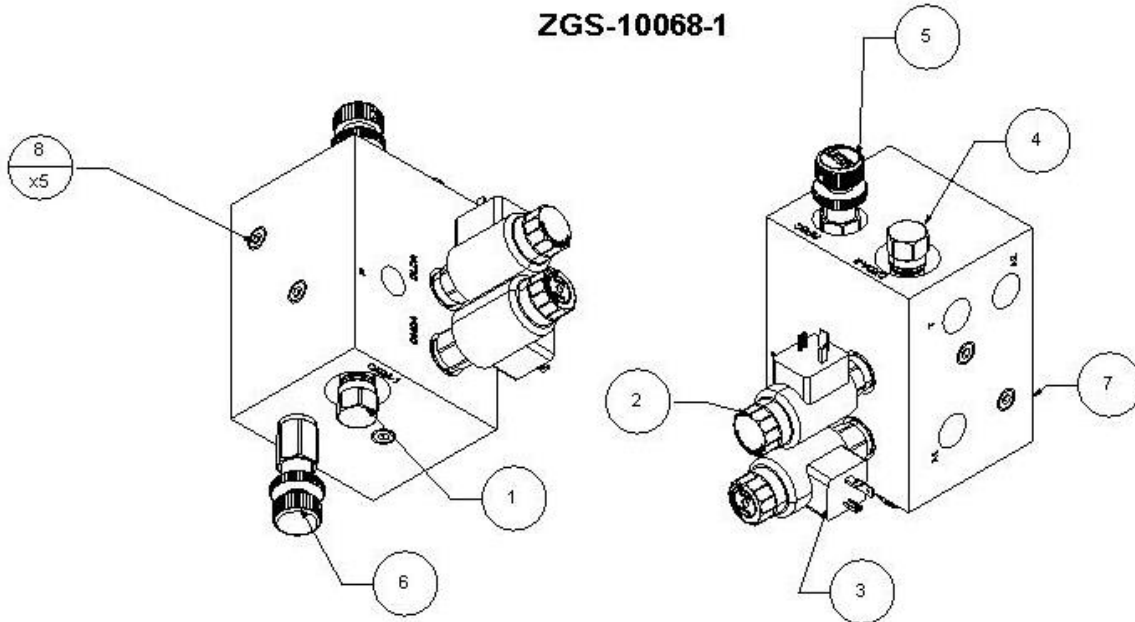

Item	Qty	Part Number	Part Name	Revision
1	1	CXDA XAN	Free Flow Nose to Side Check Valve	
2	1	DLDA SHN 224	2 position, 2 way Directional Valve	
3	1	DMDA SAN 224	2 position, 3 way Directional Valve	
4	1	CXDA XDN	Free Flow Check Valve	
5	1	RPEC KBN	Pilot Operated, Balanced Piston Relief Valve	
6	1	SCCA KAN	Direct Acting Sequence with Rev Flow Check	
7	1	171-623	Hyd Manifold Block	
8	5	#4 SAE Plug	#4 SAE Plug	

Document Title		ZGS-10000-X-X Hydraulic Rescue Hoist Ground Support Equipment		
Document No.	Rev	Document Type	Release Date	
ZOM-10000-X	H	Operation & Maintenance Manual	Sept 20, 2022	

ZGS-11064-3

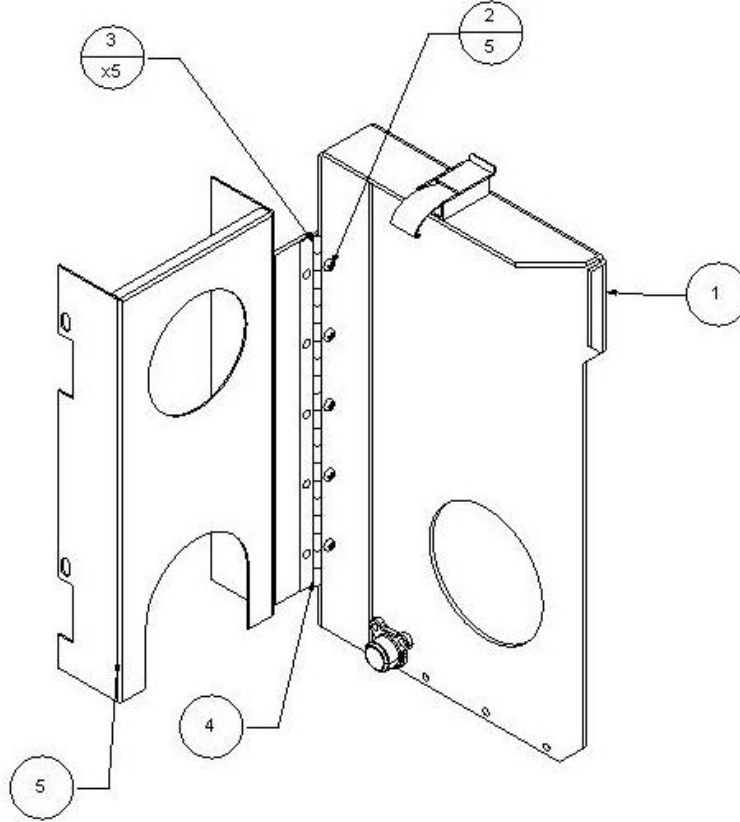

Item	Qty	Part Number	Part Name	Rev
1	1	ZGS-10328-5	Capstan Cover Assy CE	
2	5	1345	8 32 x .38	
3	5	2551	8-32 nut	
4	1	ZGS-11354-1	Hinge 10	
5	1	ZGS-10080-1	Chain Guard Upper	D

Document Title		ZGS-10000-X-X Hydraulic Rescue Hoist Ground Support Equipment		
Document No.	Rev	Document Type	Release Date	
ZOM-10000-X	H	Operation & Maintenance Manual	Sept 20, 2022	

ZGS-10328-5

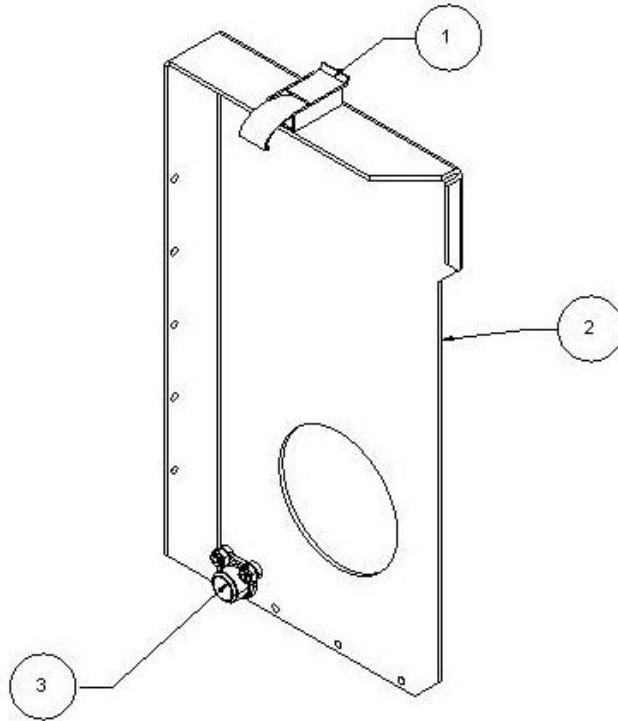

Item	Qty	Part Number	Part Name	Rev
1	1	97-50-110-12	Latch- Southco	
2	1	ZGS-10042-1	Capstan Cover	G
3	1	Part of BPR 415	Actuator	

Document Title		ZGS-10000-X-X Hydraulic Rescue Hoist Ground Support Equipment		
Document No.	Rev	Document Type	Release Date	
ZOM-10000-X	H	Operation & Maintenance Manual	Sept 20, 2022	

ZGS-10743-1

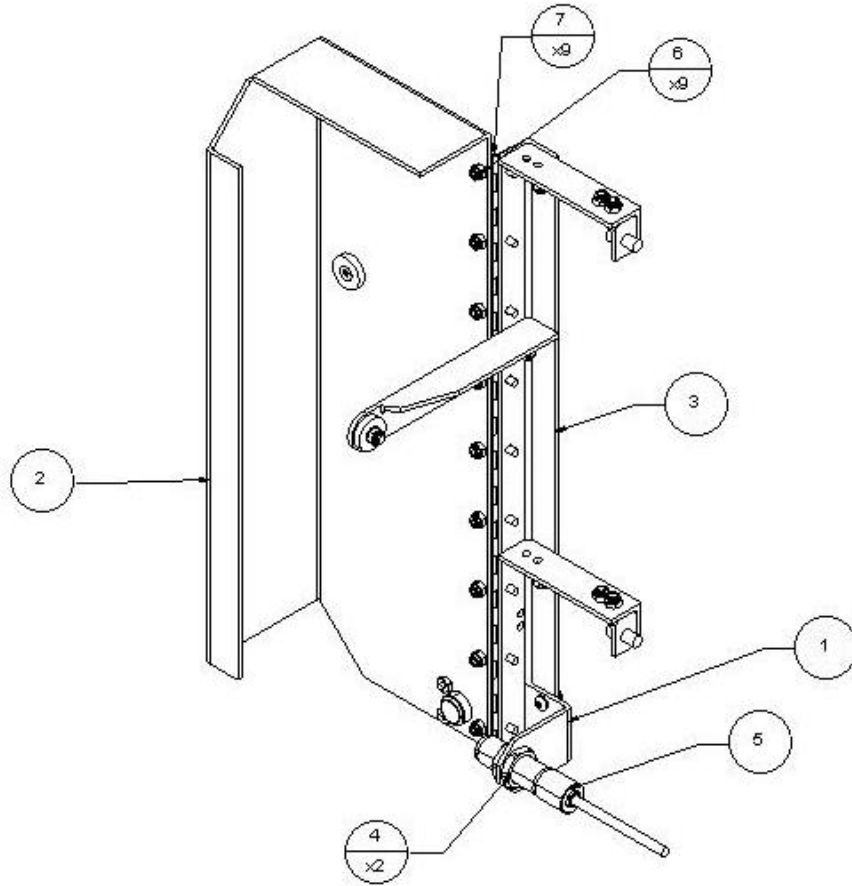

Item	Qty	Part Number	Part Name	Rev
1	1	ZGS-10893-1	Sensor Bracket	
2	1	ZGS-10809-1	Upright Cover Subassembly	A
3	1	ZGS-10808-1	Upright Cover Frame	
4	2	Included with Sensor	Sensor Nut	
5	1	BPR-415014	Sensor	
6	9	2551	8-32 nut	
7	9	1345	8 32 x .38	

Document Title		ZGS-10000-X-X Hydraulic Rescue Hoist Ground Support Equipment		
Document No.	Rev	Document Type	Release Date	
ZOM-10000-X	H	Operation & Maintenance Manual	Sept 20, 2022	

ZGS-10809-1

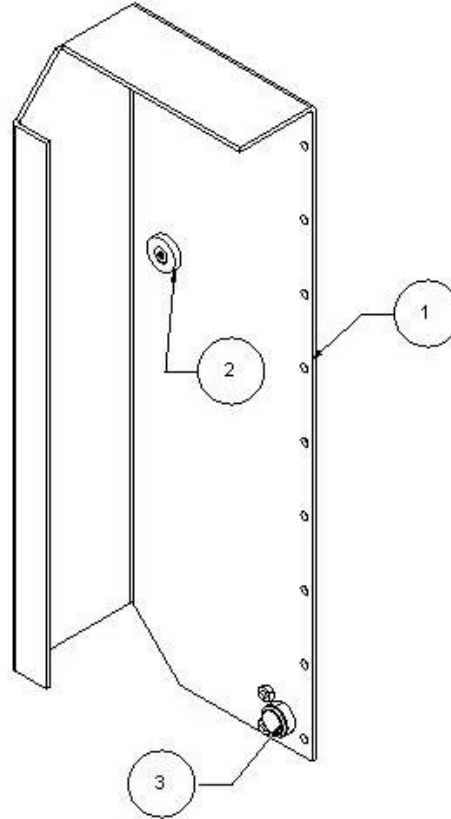

Item	Qty	Part Number	Part Name	Rev
1	1	ZGS-10759-1	Upright Cover	A
2	1	RX033CS-N	Magnet North	
3	1	Part of BPR 415	Actuator	

Document Title		ZGS-10000-X-X Hydraulic Rescue Hoist Ground Support Equipment		
Document No.	Rev	Document Type	Release Date	
ZOM-10000-X	H	Operation & Maintenance Manual	Sept 20, 2022	

ZGS-10316-1

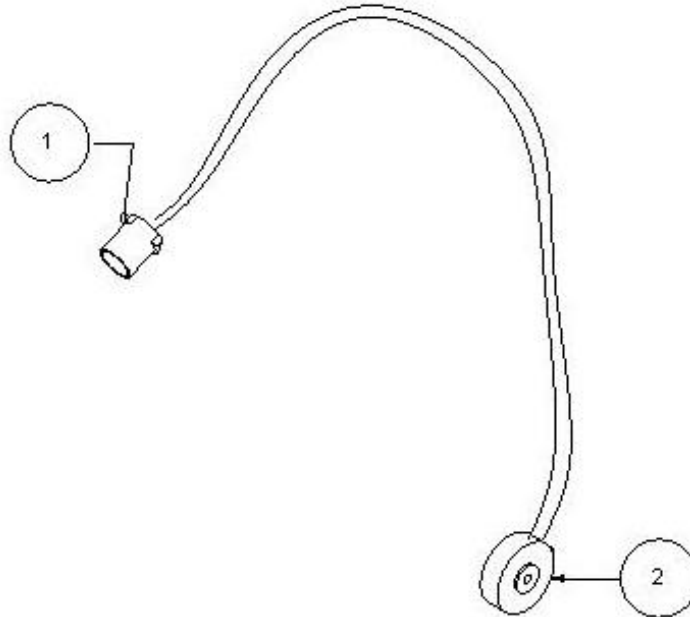

Item	Qty	Part Number	Part Name	Rev
1	1	MS3116F8-4S	Plug Connector load	
2	1	ZGS-11099-2	Thru Hole Load Cell	B

Document Title		ZGS-10000-X-X Hydraulic Rescue Hoist Ground Support Equipment		
Document No.	Rev	Document Type	Release Date	
ZOM-10000-X	H	Operation & Maintenance Manual	Sept 20, 2022	

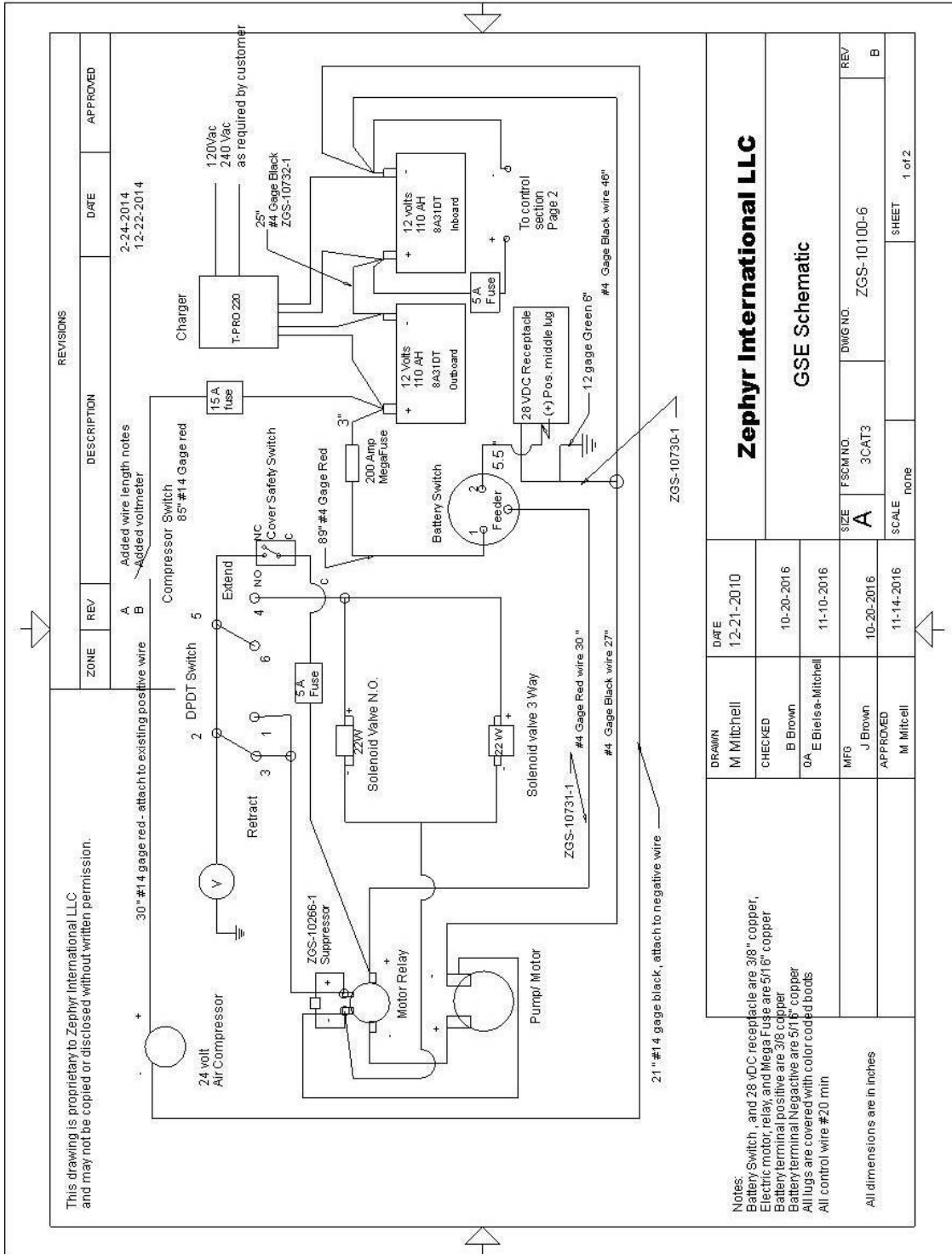

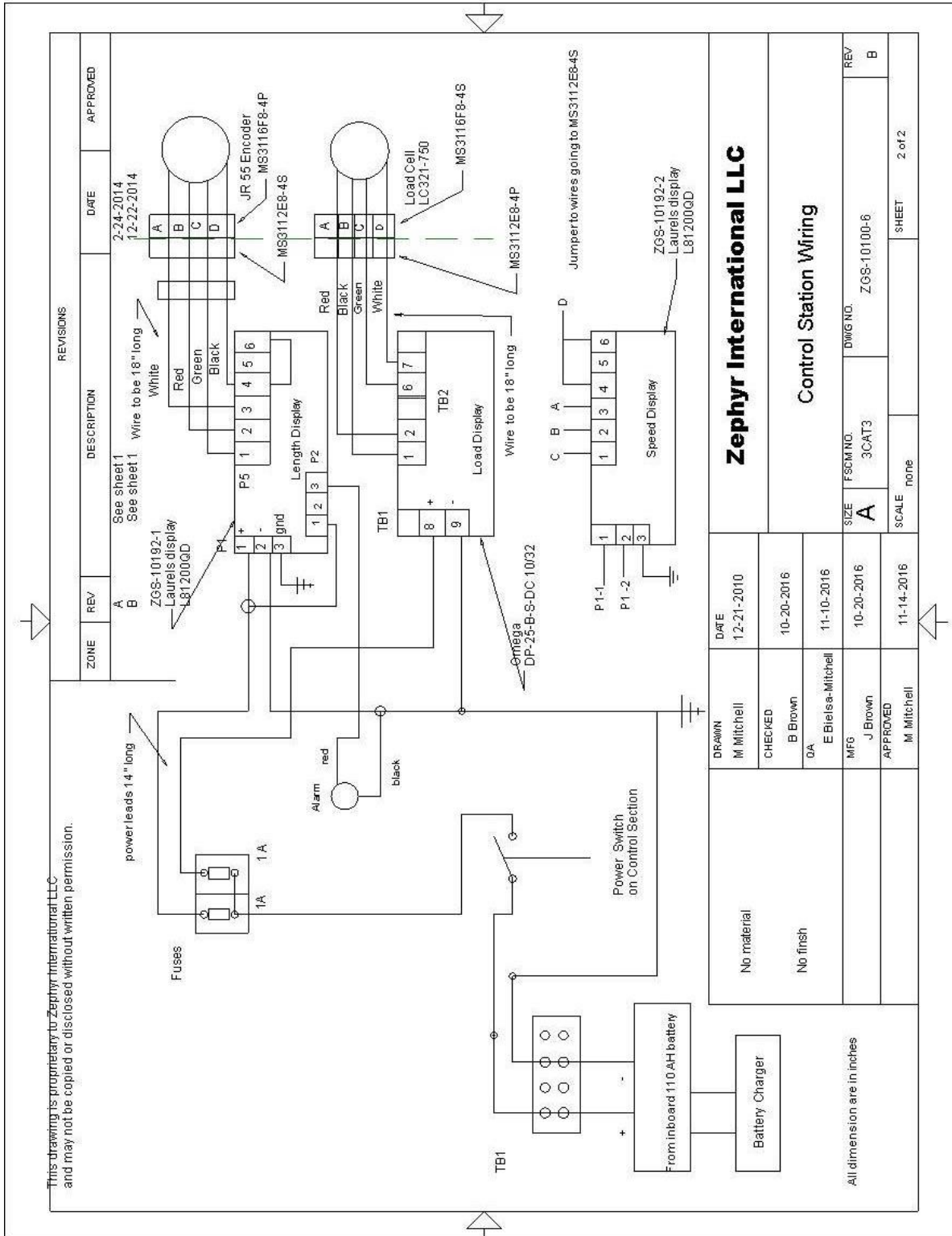

Zephyr International LLC		GSE Schematic	
DATE	12-21-2010	SIZE	A
DRAWN	M Mitchell	FSCM NO.	3CAT3
CHECKED	B Brown	DWG NO.	ZGS-10100-6
0A	E Bielsa-Mitchell	REV	B
MFG	J Brown	SCALE	none
APPROVED	M Mitchell	SHEET	1 of 2

Document Title		ZGS-10000-X-X Hydraulic Rescue Hoist Ground Support Equipment		
Document No.	Rev	Document Type	Release Date	
ZOM-10000-X	H	Operation & Maintenance Manual	Sept 20, 2022	

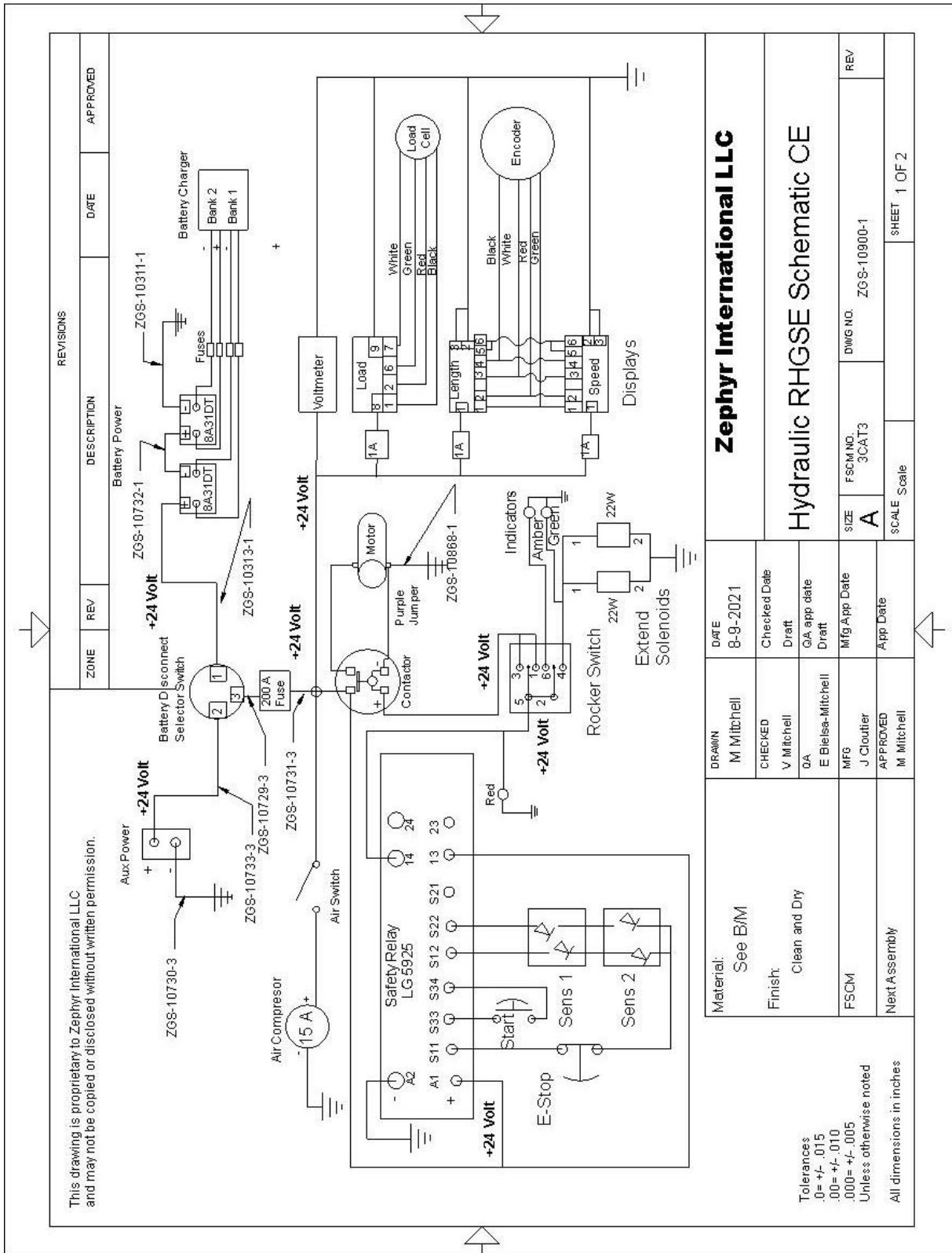

Document Title		ZGS-10000-X-X Hydraulic Rescue Hoist Ground Support Equipment	
Document No.	Rev	Document Type	Release Date
ZOM-10000-X	H	Operation & Maintenance Manual	Sept 20, 2022



Document Title		ZGS-10000-X-X Hydraulic Rescue Hoist Ground Support Equipment		
Document No.	Rev	Document Type	Release Date	
ZOM-10000-X	H	Operation & Maintenance Manual	Sept 20, 2022	

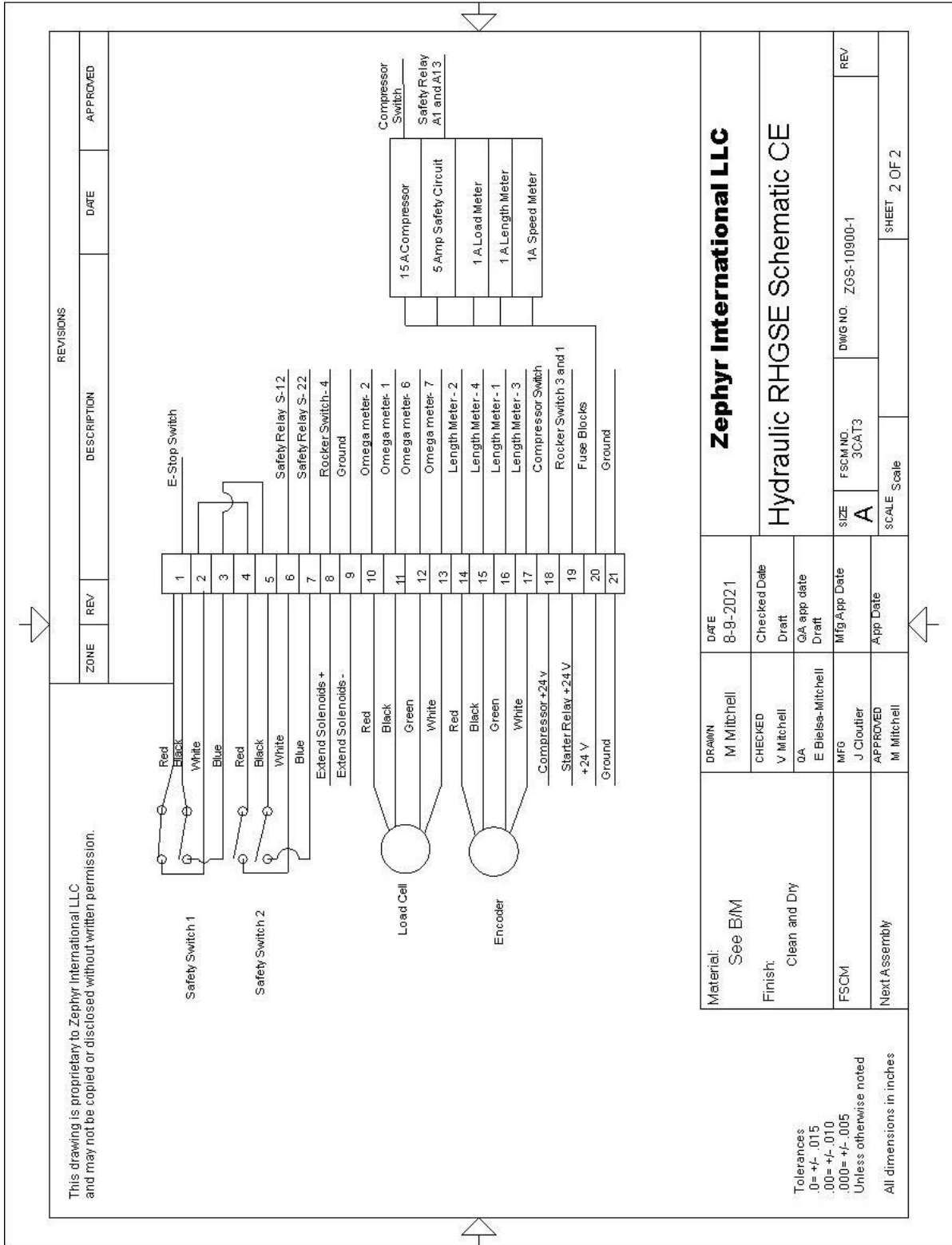



Zephyr International LLC	
Hydraulic RHGSE Schematic CE	
DATE	8-9-2021
Checked Date	Draft
QA app date	Draft
Mfg App Date	
App Date	
DRAWN	M Mitchell
CHECKED	V Mitchell
QA	E Bleisa-Mitchell
MFG	J Cloutier
APPROVED	M Mitchell
Material:	See B/M
Finish:	Clean and Dry
FSCM	
Next Assembly	
SIZE	A
FSCM NO.	3CAT3
DWG NO.	ZGS-10900-1
SCALE	Scale
SHEET	2 OF 2

Tolerances
 .0= +/- .015
 .00= +/- .010
 .000= +/- .005
 Unless otherwise noted
 All dimensions in inches

Document Title		ZGS-10000-X-X Hydraulic Rescue Hoist Ground Support Equipment		
Document No.	Rev	Document Type	Release Date	
ZOM-10000-X	H	Operation & Maintenance Manual	Sept 20, 2022	

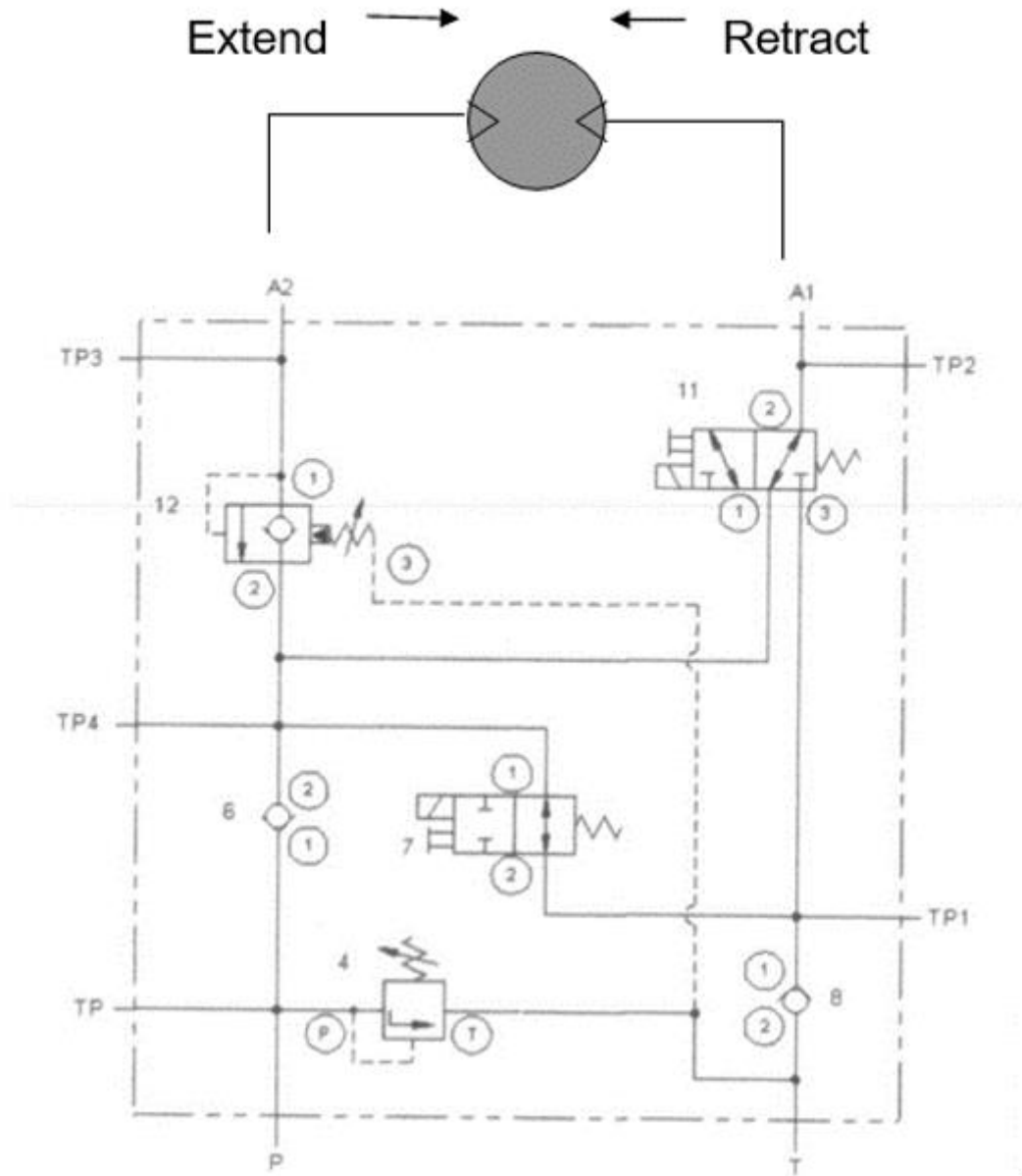
Hydraulic System Schematic



Document Title		ZGS-10000-X-X Hydraulic Rescue Hoist Ground Support Equipment		
Document No.	Rev	Document Type	Release Date	
ZOM-10000-X	H	Operation & Maintenance Manual	Sept 20, 2022	

8 Technical Support

Please contact Zephyr International LLC with any questions.

Online Support

Visit website at <http://members.zephyrintl.com/> and sign up for the Members Only section.

Register your serial number information and identify a point of contact for future service bulletin release(s).

Browse available information and resources

Technical Zephyr Support

Email: info@zephyrintl.com

Phone: 1-843-365-2675

Document Title		ZGS-10000-X-X Hydraulic Rescue Hoist Ground Support Equipment		
Document No.	Rev	Document Type	Release Date	
ZOM-10000-X	H	Operation & Maintenance Manual	Sept 20, 2022	

9 Document Revision History

	Rev	Revision Date	Revision Location	Revision Description
1	REV A	8/10/2020	All pages	Standardized manual. Added Warnings, Cautions, and notes throughout text. Capstan and roller shelf life included. Captive screws on lubridryer added. Changed Rotatub Slip Clutch values from 3-5 lbs. to 2-3 lbs.
2	REV B	09/17/2020	15,17,18,23,52	Added new load meter. Changed spooler description and pics to reflect new white material.
3	REV C	08/05/2021	11,42,43,50,61,89	Validation of operations added. Changed platen Slip Clutch values from 5-6 lbs. to 3-4lbs. Added specialty tooling for maintenance. Updated scaling new load meter instructions. Revision History added.
4	REV D	08/31/2021	All pages	Document was updated to reflect all the new safety upgrades and isometrics.
5	REV H	9/29/22	All pages	Document was updated to incorporate all versions of Hydraulic RHGSE.