

This drawing is proprietary to Zephyr International LLC and may not be copied or disclosed without written permission.

REVISIONS				
ZONE	REV	DESCRIPTION	DATE	APPROVED
	A	Revised and Redrawn	8-25-2008	

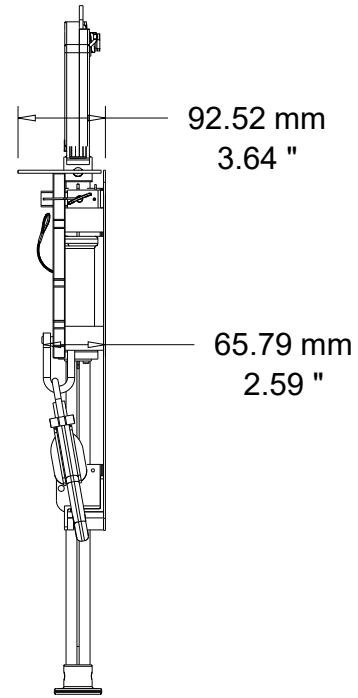
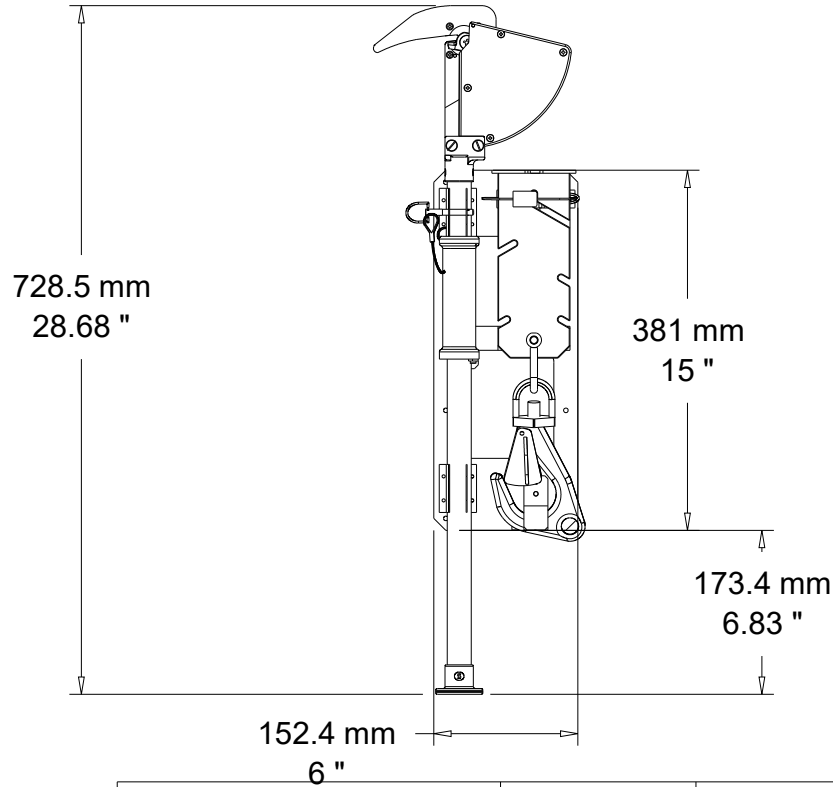
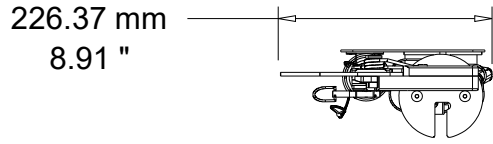

Tolerances
 .0= +/- .020
 .00= +/- .010
 .000= +/- .001
 .0000= +/- .0005

Material: See B/M	DRAWN MM	DATE 5-11-2006	Zephyr International LLC			
Finish: Clean and dry	CHECKED					E-Kit
	QA					
	MFG		SIZE A	FSCM NO. 3CAT3	DWNG NO. ZL-1100-1	REV A
	APPROVED		SCALE 1:8		SHEET 1 of 2	

This drawing is proprietary to Zephyr International LLC and may not be copied or disclosed without written permission.

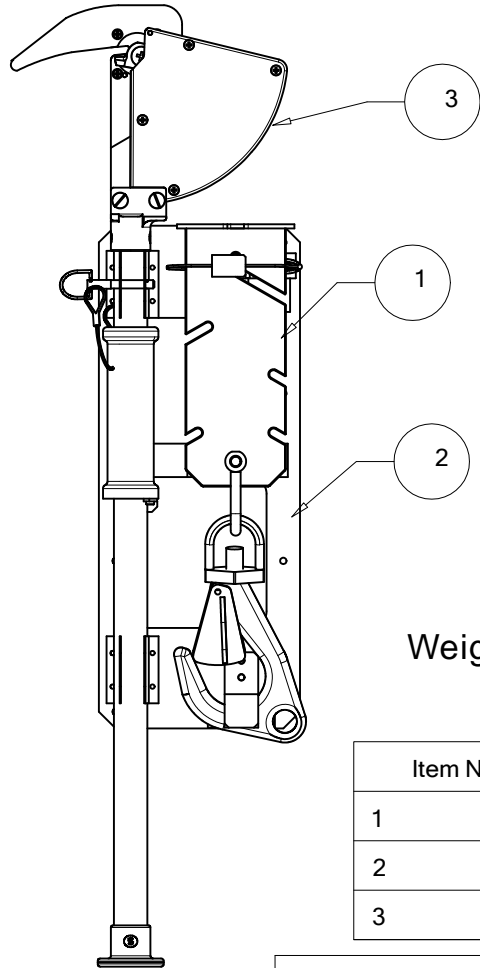

Weight = 6 lbs (2.7 kg)

Mounting holes can be modified as required by installation

REVISIONS				
ZONE	REV	DESCRIPTION	DATE	APPROVED

A		Revised and Redrawn	8-25-2008	
---	--	---------------------	-----------	--

152.4 mm
6"

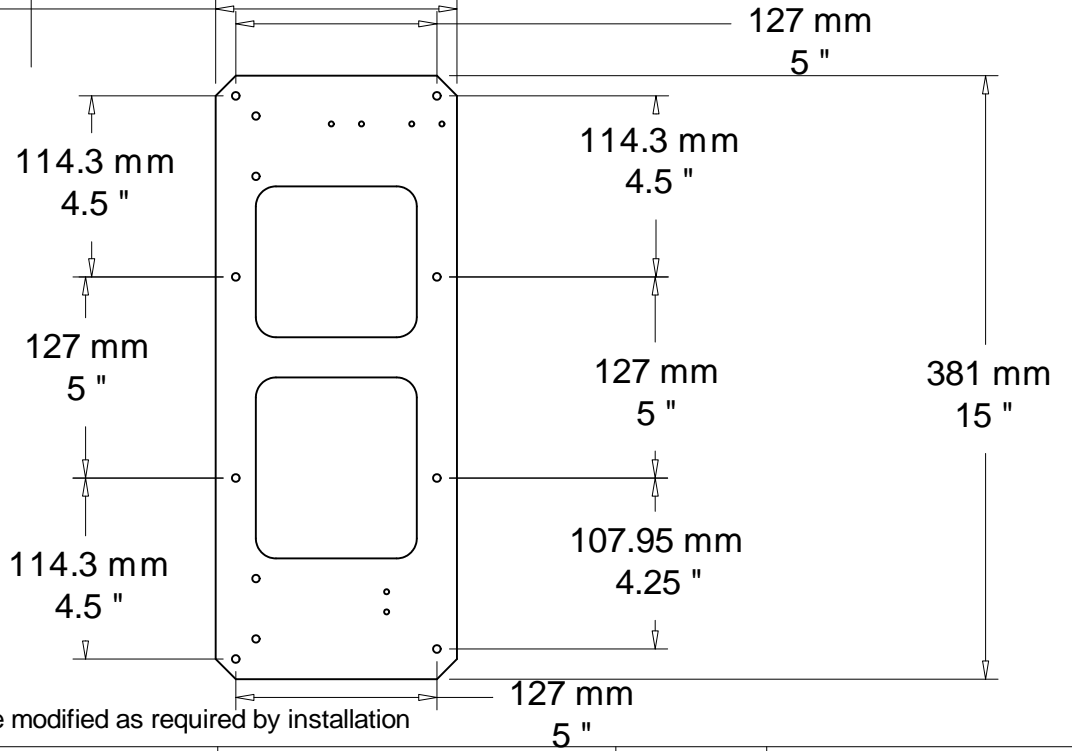

Item Number	Quantity	Part Number	Part Name	Revision	Comment
1	1	ZL-6000-3	QuickSplice		
2	1	ZL-1000-4	AxelCut and QuickSplice Mount	B	
3	1	ZL-1000-1	AxelCut		

Material: See B/M	DRAWN MM	DATE 5-11-06	Zephyr International LLC			
	CHECKED					
	Finish: Clean and dry	QA		E-Kit		
	MFG		SIZE A			
	APPROVED		SCALE		SHEET	2 of 2

Tolerances
 .0= +/- .020
 .00= +/- .010
 .000= +/- .001
 .0000= +/- .0005